

dnd[®]



26—
27

Un catalogo che racconta Dnd e presenta le sue collezioni di maniglie, realizzate con esperienza e passione in nome del miglior design e del fatto bene.

A catalogue that narrates the story of Dnd whilst presenting the company's handle collections; each created with expertise and passion in the name of top design and high quality.

dnd[®]

**handles
with care**

**26—
27**









Maniglie che sono frutto di cura, attenzione, passione. Dnd mette la sua sapienza produttiva al servizio della migliore creatività, coinvolgendo nello sviluppo delle collezioni progettisti di valore per focalizzare l'attenzione verso il mondo del design, arricchire la gamma dei prodotti e soddisfare al meglio la progettazione degli interni contemporanei.













Handles that are the result of care, attention and passion. Dnd puts its manufacturing expertise at the service of the most brilliant creativity, collaborating with outstanding designers to develop collections that shine a light on the world of design, enrich its range of products and fully satisfy the needs of contemporary interior design.









INDICE / INDEX

MANIGLIE ALTAGAMMA HIGH-END DOOR HANDLES

ANIK		100	BLEND 02		193	DUE		177
ANIK 02		102	BLEND AG <small>NEW</small>		194	DUNE		118
ANIK BRILLIANT		104	BLIP		246	EDRA 02		214
ANIK BRILLIANT 02		106	BOOLE		167	ELENA		258
ANIK LINE		108	C-1918		210	ELEONORA		150
ANIK LINE 02		110	CHANGE B 02		228	ELEONORA 02		152
ARETÈ		222	CLOE		230	ELLIPSE <small>NEW</small>		95
ARETÈ 02		220	CLOE 02		232	ELLIPSE BRILLIANT <small>NEW</small>		98
ARETÈ L		224	CRISALIDE		113	FLU K E		218
ARETÈ L 02		226	CRISALIDE MINI		116	FREELY		164
ART		244	DOLCE		240	GINEVRA		216
BLEND		189	DROP		197	GINKGO		159





























GINKGO BILOBA		162
HAVANA		238
(I N) FI N ITO		129
INTAKE		208
ISABELLA		144
LEVA		89
LEVA MIRROR		91
LEVANTE		173
LINEAR		242
LUCREZIA		146
LUCREZIA 02		148
LUXURY		200

LUXURY 02		202
MADELEINE		205
MJ		259
OVUM		250
PALM	 NEW	81
PENCIL	 NEW	85
POD		125
PROJECT		234
PROJECT 02		236
PROJECT ZANCATA		254
PROJECT ZANCATA 02		255
SAFETY		170

SHORT		212
SILVYANA		256
THELMA		257
TIMELESS		141
TWIST		252
TWIST 02		253
VITA		248
VIVA!		155
ZEPPELIN		185

INDICE / INDEX

MANIGLIE PREMIUM PREMIUM DOOR HANDLES

ARTIK		302	LUCE 02		280	SOCHIC 02		291
CHOP		286	LUCE P		282	SOCHIC L		292
ELLE		301	LUCE P 02		284	SOCHIC L 02		293
ESA		288	MINIMA		299	SPOT		266
FOLD		294	PLURIS		268	TIPO-Z		303
FOLD 02		295	QUATTRO 02		300			
HOLLY		298	S40		304			
IKI		275	S50		304			
JOY		296	S60		305			
JOY 02		297	SAN		271			
KIND OF		263	SAN 02		273			
LUCE		278	SOCHIC		290			

MANIGLIE CLASSICHE CLASSIC DOOR HANDLES

AIRONE  318

ANGELA  308

APPIA  315

AURORA  311

BARBARA  310

BEAUTY  318

BRUXELLES  318

CLASSIC  312

DANIELA  319

FEDORA  313

FIORE  316

FIorenZA  317

GIORGIA  319

LADY  319

LATINA  314

LIRICA  320

MARTA  320

SIMONA  309

TIFFANY  320

SISTEMI PER PORTE E FINESTRE DOOR AND WINDOW SYSTEMS

36

FINITUR
E
FINISHE
S 56

FINITUR **forte**[®]
forte[®] FINISHES 58

NEW
HOSPITALITY
KIT HOTEL 324

NEW
COMPACT
SYSTEM 328

NEW
COMPONENTI PER
PORTE BLINDATE
ACCESSORIES FOR
ARMORED DOOR 332

INDICE / INDEX



MANIGLIONI PULL HANDLES

ARETÈ	356	PENCIL	 344
ARETÈ L	357	POD	345
CLOE	355	PROJECT	364
DANIELA	367	PROJECT SPOSTATO	364
DOMUS	358	SOLID SQUARE	359
ELEONORA	349	TUBE ROUND	360
GINKGO	352	TUBE ROUND ZANCATO	361
GINKGO BILOBA	353	ZEPPELIN	348
(I N) F I N I T O	346		
LATINA	366		
LOGO	363		
LUCE	365		
LUCREZIA	354		
LUXURY	362		

MANIGLIONI PER ALZANTE SCORREVOLE PULL HANDLES FOR LIFT SLIDING SYSTEM

EDRA	372
EDRA CORTO	373
EDRA 02	370
EDRA 02 CORTO	371
LUCE	378
LUCE 02	379
LUCE P	376
LUCE P 02	377
SLIDE	374
SLIDE CORTO	375
PLACCHE INCASSO SLIDING DOOR HANDLES	380

POMOLI KNOBS

EASY	389
FIORENZA	389
LUCREZIA	387
LUCREZIA 02	388
LUCREZIA 03	388
OLIVE	 385
PALM	 384
PENCIL	 384
PROJECT	390
QUADRO	386
RING	385
RONDÒ	386
SFERA	390
TIMELESS	387

POMOLINI PER MOBILI FURNITURE KNOBS

CRISALIDE	392	TIMELESS	391
DUNE	393	ACCESSORI PER MOBILI FURNITURE ACCESSORIES	391

MANIGLIE PER PORTE SCORREVOLI SLIDING DOOR HANDLES

GINKGO TONDA	400	QUADRA	405
GINKGO QUADRA	401	RETTANGOLARE	407
MASTER TONDA	396	RING	403
MASTER QUADRA	398	RONDÒ	402
NOXIA	406	TO N D A	404

ARTICOLI VARI OTHER COMPLEMENTS

NOTTOLINI TURN & RELEASES	410	CHIAVI KEYS	426
BOCCHETTE ESCUTCHEONS	423	PLACCHE PLATES	427
FERMAPORTA DOOR STOP	426		

STORIA / HISTOR Y

Esistono territori in Italia dove la combinazione tra la storia e le storie degli uomini è diventata una mirabile fusione: uno di quei luoghi è la Val Sabbia, territorio prealpino bresciano racchiuso tra il lago di Garda a est e la Val Trompia a ovest. Una valle caratterizzata da un'antica dedizione per la trasformazione dei metalli, le lavorazioni siderurgiche, la generazione di oggetti forti – ottenuti a colpi di maglio, fusione, pressofusione – in antiche fucine che nel tempo si sono trasformate in solide realtà industriali. È in questo contesto che si innesta la storia di Angelo Martinelli che, con i fratelli, nel 1968 fonda a Nozza l'azienda FMN Martinelli (Fratelli Martinelli Nozza), specializzata nella produzione di maniglie e accessori per porte e finestre.

There are territories in Italy where the combination of history and the stories of people has become an admirable blend: one of those places is Val Sabbia, a pre-Alpine zone near Brescia bordered by Lake Garda to the east and Val Trompia to the west. A valley known for its historic vocation for the working of metals, the making of steel, the generation of strong objects – made by wielding a hammer, by casting, by die-casting – in old forges that have been transformed, over time, into solid industrial companies. This is the context for the story of Angelo Martinelli, who with his brothers, in 1968, in the town of Nozza, founded the company FMN Martinelli (Fratelli Martinelli Nozza), specializing in the production of handles and accessories for doors and windows.



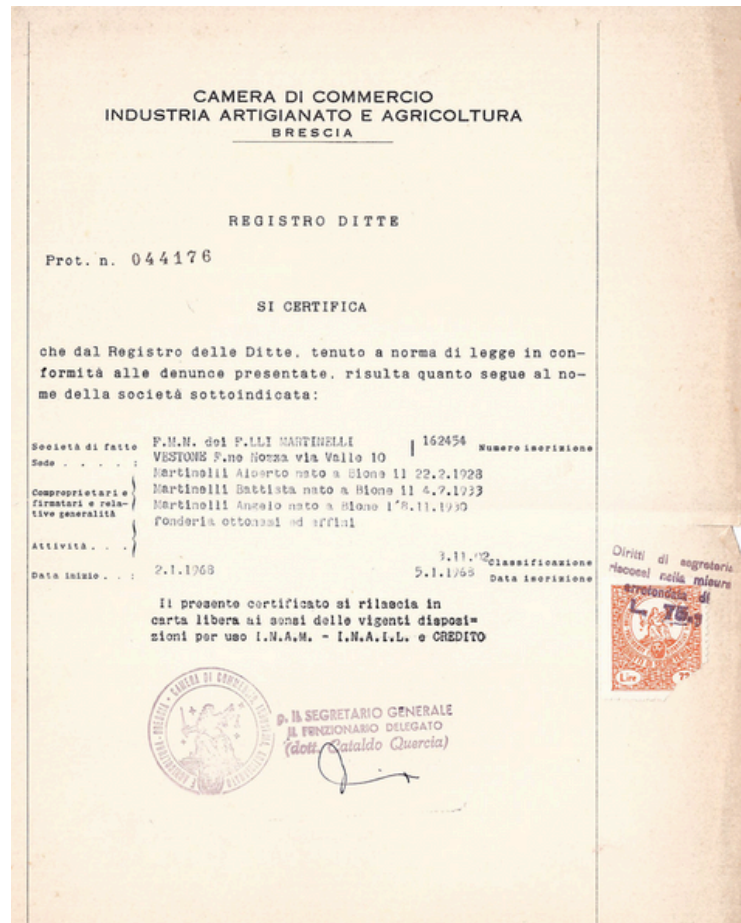

Nel 1998 nasce il marchio Dnd con l'obiettivo di proporre al mercato maniglie di qualità, frutto di una progettazione d'eccellenza sviluppata in collaborazione con designer di fama nazionale e internazionale. Il design viene posto al centro del processo creativo, dando vita a oggetti che si configurano come autentici elementi d'arredo. In oltre 55 anni di sviluppo, l'azienda si è evoluta e concentrata sulla ricerca e sull'incremento della produzione, rinnovandone i processi e specializzandosi nella lavorazione e nella rifinitura dei metalli destinati alla produzione delle maniglie.

In 1998, the Dnd brand was established with the aim of offering the market quality handles, the result of an excellence-driven design process developed in collaboration with a network of renowned Italian and international designers. Design is placed at the core of the creative process, giving rise to objects conceived as true furnishing elements. During its 55 years of business, the company has developed and evolved continuously by focusing on research, increasing production, renewing processes and specialising in metal working and finishing, with the end product being brass handles, amongst others.

AZIENDA / COMPANY

Dnd è un punto di riferimento internazionale per la realizzazione di maniglie che guardano alla qualità e al progetto. Se inizialmente è stato il territorio ad aver ispirato la creazione dell'azienda, oggi è l'azienda che restituisce alla Val Sabbia un ruolo chiave per lo sviluppo dei prodotti, incoraggiando e sostenendo una rete di realtà artigianali a cui demandare specifici passaggi di produzione e finitura: un indotto che costituisce un grande valore, ideale estensione e completamento di un processo che garantisce l'eccellenza dei prodotti che Dnd, con la sua ricerca, mira a realizzare.

Dnd is an international benchmark when it comes to producing quality and design-oriented handles.

While at first it was the territory that drove the creativity of the company, today it is the company that plays a key role in Val Sabbia for the development of products, encouraging and supporting a network of crafts firms from which to order specific phases of production and finishing: a chain of manufacture that represents a remarkable value, an ideal extension and completion of a process that ensures the excellence of the products that Dnd, through its research, sets out to create.





Dnd oggi è diretta da Vilma Martinelli con i figli Pietro e Simona. Insieme a una affiatata squadra di collaboratori, vivono e guidano ogni giorno l'azienda come una fucina di idee in grado di coniugare la lunga esperienza produttiva acquisita con la progettualità degli architetti e dei designer di valore che vengono puntualmente coinvolti nel disegno dei prodotti. Dal 2017 la governance ha scelto Giulio Iacchetti come direttore artistico: un designer industriale di grande talento che è impegnato attivamente nel percorso di crescita dell'azienda, nello sviluppo del catalogo, nella selezione e nell'inclusione dei progettisti e dei consulenti per il mondo Dnd.

Dnd is currently run by Vilma Martinelli and her sons, Pietro and Simona. Together with a close-knit team of collaborators, they ensure the company operates on a daily basis, like a hothouse of ideas capable of combining their extensive manufacturing experience with the planning skills of architects and designers who are regularly involved in product design. Since 2017, the governance has entrusted the role of artistic director to Giulio Iacchetti: a highly talented industrial designer who has actively contributed to the company's growth path, catalogue development, and the selection and inclusion of designers and consultants for Dnd.

VALORI / VALUES

Valori come strategia e come progetto, da seguire ogni giorno nel presente e verso il futuro. Dnd ne identifica cinque: integrità, passione, innovazione, miglioramento e sinergia.

Values like strategy and design that are stringently followed every day with both the present and future in mind. Dnd has identified five main values: integrity, passion, innovation, improvement and synergy.





MADE IN ITALY



Prodotte maniglie di qualità e completamente Made in Italy da oltre cinquantacinque anni: una scelta strategica di lunga data che si fonda sui valori della cultura aziendale italiana e sul profondo legame che Dnd ha nei confronti del suo territorio e del suo distretto, la Valle Sabbia in provincia di Brescia. Dnd è Made in Italy con l'orgoglio di realizzare prodotti grazie al sapere, alla ricerca, allo stile e alla cura che oggetti di piccole dimensioni – come le maniglie – richiedono. L'eccellenza e il valore del design italiano si fondano da sempre sullo sviluppare, lavorare, rifinire e collaudare in Italia: passaggi importanti a tutela di prodotti di qualità.

To produce high-quality handles, completely Made in Italy, for over fifty-five years: a long-term strategy based on the values of an Italian corporate culture and the deep bond between Dnd and Valle Sabbia in the province of Brescia, its district and its territory. Dnd is Made in Italy with pride, to create products thanks to know-how, research, style, and all the care that has to go into objects of small size such as handles. The excellence and value of Italian design are constants in the development, workmanship and testing, all done in Italy: important phases to guarantee products of the highest quality.

Dalla creatività ai materiali, dal disegno al progetto, dalla produzione alle finiture, maniglie che sono da sempre fatte in Italia e fatte di Italia per entrare nelle case più belle e accoglienti, per caratterizzare progetti architettonici di pregio e per soddisfare al meglio le personalizzazioni del mondo contract, in Italia e nel mondo.

From creativity to materials, the drawing to the project, the production to the finishing, handles that are always made in Italy and made of Italy, to enter the most beautiful, appealing homes, to enhance outstanding works of architecture, to offer an optimal response to needs of customization in the contract sector, in Italy and the world.



Azienda con certificazione
sistema di qualità
UNI EN ISO 9001:2015

- Progettazione ottimizzata
- Costante formazione delle risorse umane
- Ambiente di lavoro controllato
- Produzione tecnologicamente avanzata
- Monitoraggio instancabile

A company with
UNI EN ISO 9001:2015 quality
system certification

- Optimized design
- Constant training of human resources
- Controlled working environment
- Technologically advanced production
- Continuous monitoring

MADE TOGETHER

L'azione di una realtà industriale si svolge anche in relazione con enti e associazioni che condividono con essa percorsi, tappe e impegni. Dnd è orgogliosa di essere parte di organizzazioni che mettono al centro della loro azione il saper fare italiano, il design, le comunità e i loro distretti.

Being an industrial company also involves working alongside organisations and associations that share the same paths, stages and commitments. Dnd is proud to belong to organisations that put Italian know-how, design, communities and their districts at the centre of their action.



CONFINDUSTRIA
Brescia

Confindustria

In quanto impresa manifatturiera, Dnd è protagonista di quel “saper fare” che è da sempre uno degli asset dell'Italia. Per questo motivo, e per la volontà di fare rete con le aziende del territorio, Dnd è associata a Confindustria Brescia, tra le più antiche associazioni industriali del Paese, di cui fanno parte circa 1300 realtà.

As a manufacturing company, Dnd is the flag bearer of a “know-how” that has always been one of Italy's assets. For this reason and the desire to network with local companies, Dnd is registered with Confindustria Brescia, which is one of the oldest industrial associations in the country, with roughly 1300 companies under its wing.



Fabbrichiamo il futuro

Il BAQ (Bollino per l'Alternanza di Qualità) riconosce le imprese che si distinguono per la qualità dei percorsi di Alternanza Scuola-Lavoro, promuovendo collaborazioni efficaci con scuole secondarie di secondo grado e centri di formazione e il loro impegno nell'inserimento professionale delle nuove generazioni.

The BAQ (Quality Work-Based Learning Label) recognizes companies that stand out for the quality of their work-based learning programs, promoting effective collaborations with upper secondary schools and training centers, and highlighting their commitment to supporting the professional integration of younger generations.

ADMEMBER



ADI Member

Essere socio di ADI, Associazione per il disegno industriale, per Dnd significa avere un ruolo attivo nel mondo del progetto italiano. Ed essere, insieme alle altre imprese e ai professionisti associati, tra i protagonisti dell'evoluzione del disegno industriale come fenomeno culturale ed economico del paese.

Dnd believes that being a member of ADI – Italy's Association for Industrial Design – means playing an active role in the world of Italian design. And to be, together with other companies and associated professionals, one of the prime examples of how industrial design has evolved as a cultural and economic phenomenon in this country.

Federlegno

Dnd sviluppa e realizza maniglie per porte, infissi e mobili, in dialogo costante con il mondo dell'arredo. L'adesione a Federlegno consente di partecipare a un'attività continua di formazione, a una consulenza in ambito normativo e di guardare in una direzione strategica per affrontare nuovi mercati e nuove sfide.

Dnd develops and creates handles for doors, fixtures and furniture, by constantly liaising with the furnishing sector. Becoming a member of Federlegno has allowed the company to participate in on-going training activities, receive adequate legal consultancy and be provided with a strategic direction to enter new markets and face new challenges.

Fondo territoriale per la Valle Sabbia

L'attenzione e la salvaguardia del territorio si esprimono in diverse forme. Dnd ha aderito al Fondo Territoriale per la Valle Sabbia per promuovere opportunità di crescita e coesione e sostenere la resilienza della valle, attraverso la ricerca di fondi per politiche di intervento dedicate alle fasce sociali più deboli.

The local area is looked after and protected in different ways. Dnd joined the Local Fund for Valle Sabbia to promote opportunities for growth and cohesion, whilst supporting the valley's resilience by helping acquire funds to develop intervention policies dedicated to society's most vulnerable groups.



Una veduta del territorio: Lago d'Idro e Valle Sabbia, in provincia di Brescia.
A view of the area: Lake Idro and Valle Sabbia, in the Italian province of Brescia.

Photo: Federico Pasinetti

MAESTRIA ARTIGIANALE / CRAFTSMANSHIP

In Dnd, la maestria artigianale è un valore che guida ogni gesto produttivo. Un sapere costruito nel tempo, capace di dialogare con le tecnologie più evolute, dà forma a maniglie in cui qualità, precisione e bellezza convivono in perfetto equilibrio. Attraverso processi di stampaggio e pressofusione, materiali nobili come ottone, zama e alluminio vengono trasformati con competenza e sensibilità, rispettandone l'essenza e valorizzandone le potenzialità.

At Dnd, craftsmanship is a core value that guides every step of the production process. A body of knowledge built over time, capable of engaging with the most advanced technologies, gives shape to handles in which quality, precision, and beauty coexist in perfect balance. Through stamping and die-casting processes, noble materials such as brass, zamak, and aluminum are transformed with skill and sensitivity, respecting their essence and enhancing their potential.





È in questa attenzione profonda alla materia e al dettaglio che prende vita un design autentico, pensato per durare nel tempo e per essere vissuto ogni giorno. Un design che supera la funzione, diventando gesto, esperienza e segno distintivo nello spazio, capace di raccontare l'identità Dnd attraverso forme essenziali, superfici ricercate e una qualità percepibile al primo tocco.

It is this deep attention to material and detail that gives rise to authentic design, created to endure and to be experienced every day. A design that goes beyond function, becoming gesture, experience, and a distinctive presence within space-able to express the Dnd identity through essential forms, refined surfaces, and a quality that is immediately perceptible to the touch.



RESPONSABILITÀ / RESPONSIBILITY



Dnd è felice di promuovere ogni giorno azioni e processi attenti all'ambiente e si impegna in diversi progetti legati alla sostenibilità al fine di migliorare la salute del luogo di lavoro e sviluppare un senso di responsabilità come strategia e come scelta.

Dnd is happy to promote environmentally-friendly actions and processes every day, and is involved in a number of sustainability-related projects to put health at the centre of the workplace and develop a sense of responsibility, as a strategy and a choice.



LA NOSTRA ENERGIA OUR ENERGY

L'impianto fotovoltaico da 218 chilowatt di picco, copre gran parte del fabbisogno energetico della produzione aziendale ed è formato da 396 moduli da 550 watt di picco ciascuno. The 218-kilowatt-peak photovoltaic system, covers great amount of the company's production energy needs and consists of 396 modules, each with a peak power of 550 watts.



ENERGIA RINNOVABILE RENEWABLE ENERGY

L'energia utilizzata proviene da fonti 100% rinnovabili, una scelta certificata e consapevole che contribuisce concretamente alla tutela dell'ambiente e del pianeta nel lungo periodo.

The energy used comes from 100% renewable sources, a certified and conscious choice that concretely contributes to the protection of the environment and the planet in the long term.



VEICOLI EMISSIONI ZERO ZERO-EMISSION VEHICLES

Una flotta di veicoli 100% elettrici a zero emissioni, per una mobilità sostenibile che riduce l'impatto ambientale e riflette l'impegno concreto verso un futuro più pulito. A fleet of 100% electric, zero-emission vehicles, for sustainable mobility that reduces environmental impact and reflects a concrete commitment to a cleaner future.



FINITURE NATURALI NATURAL FINISHES

Ogni scelta produttiva riflette l'impegno a unire design e sostenibilità. La produzione delle finiture naturali riduce il consumo energetico e l'emissioni di CO2 garantendo riciclabilità totale.

Every production choice reflects the commitment to combine design and sustainability. The production of natural finishes reduces consumption and CO2

emissions while ensuring full recyclability.



PACKAGING SOSTENIBILE SUSTAINABLE PACKAGING

Il packaging segue un approccio sostenibile, combinando le scatole in cartone con imballi in cotone riciclato, per proteggere al meglio le maniglie rispettando l'ambiente.

Dnd packaging follows a sustainable approach, combining cardboard boxes with recycled cotton padding to protect handles in the best possible way while respecting the environment.



CARTA CERTIFICATA FSC® FSC® CERTIFIED PAPER

L'impegno è quello di usare il minor quantitativo di carta possibile: l'azienda ha ridotto del 50% il consumo e sceglie per listini e cataloghi solo carta certificata FSC®.

The company strives to go as paperless as possible: it has reduced consumption by 50% and solely uses FSC® certified paper for its price lists and catalogues.

IL DESIGN COME VALORE / DESIGN AS A VALUE

A partire dagli anni Duemila, Dnd ha deciso di dedicare la propria esperienza produttiva al settore del design, indirizzando con decisione la ricerca e lo sviluppo dei prodotti verso quegli standard di disegno e qualità che il mondo del progetto richiede, a livello italiano e internazionale. Fare parte del mondo del design implica la costruzione di una identità aziendale solida e consapevole, orientata con continuità e passione verso il progetto e dunque verso la creatività e l'innovazione. E verso il fatto bene, attraverso grande cura e perizia.

Since the 2000s, Dnd has chosen to dedicate its manufacturing experience to the design sector, by decisively orienting its product research and development towards the worldwide industry-specific design and quality standards, at both a national and international level. Being part of the design world implies building a concrete yet conscious corporate identity with a continuous and passionate approach to design and therefore oriented towards creativity and innovation. In addition to doing things well, with great care and expertise.

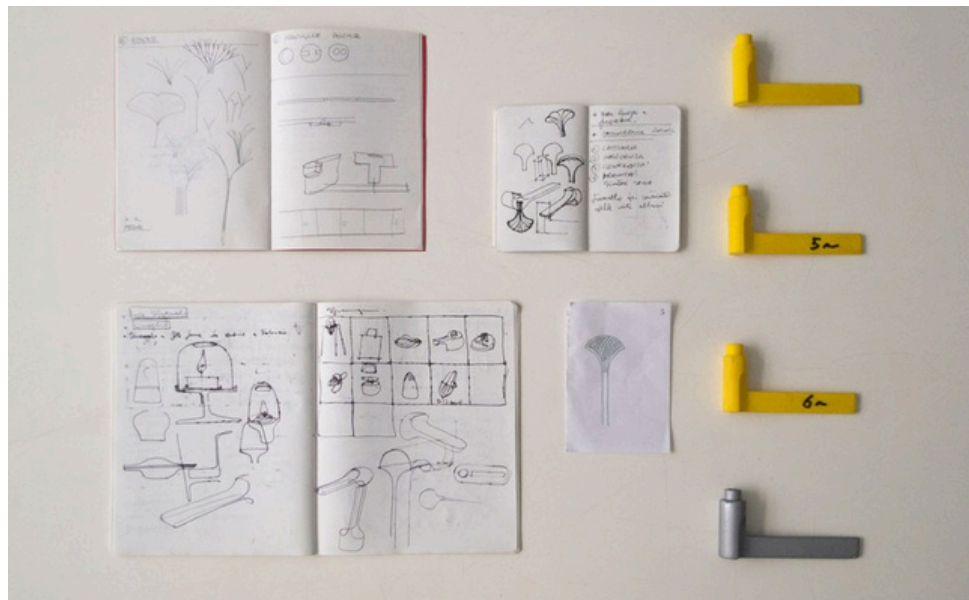

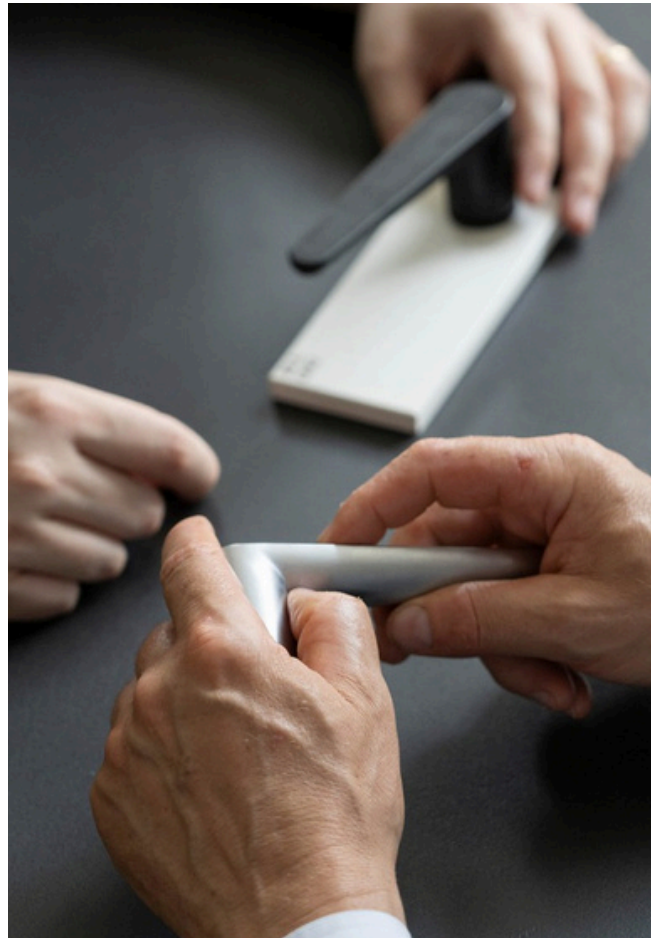

L'impegno di Dnd nel mondo del design contemporaneo è stato ulteriormente suggellato nel 2017 con il coinvolgimento di Giulio Iacchetti come direttore artistico. Questa preziosa e proficua collaborazione ha portato l'azienda a declinare con sempre maggiore puntualità il linguaggio del design nei suoi prodotti, dal disegno ai dettagli, dalle finiture all'aggiornamento tecnologico.

Le qualità delle maniglie Dnd sono riconosciute a livello internazionale e hanno ottenuto premi e riconoscimenti in importanti concorsi di design.

Dnd's commitment to the contemporary design sector was further sealed in 2017, when Giulio Iacchetti took on the role as artistic director.

This valuable and fruitful collaboration has allowed the company to more fluently express its design language through its products, from the design to the details, finishes and technological advancements.

By dint of the qualities that the Dnd handles possess, they have garnered international recognition and led to awards and special mentions in some of the major design contests.



Giulio Iacchetti

Direttore artistico Dnd
Dnd art director



Video:
Dnd al Salone del Mobile

Video:
Dnd at Salone del Mobile



archiproducts
AWARDS
WINNER
SUSTAINABILITY

Winner
Archiproducts Awards Sustainability
2025 – Palm
Design by BIG - Bjarke Ingels Group



Menzione d'Onore
Compasso d'Oro ADI
2024 – Leva
Design by Park



Winner
Good Design Awards
2017 – Ginkgo
Design by Giulio Iacchetti

archiproducts
AWARDS
WINNER

Winner
Archiproducts Awards
2025 – Palm
Design by BIG - Bjarke Ingels Group
2024 – Dynamic + Interna
Design by Giulio Iacchetti
2023 – Crisalide
Design by Elena Salmistraro
2022 – Pod
Design by Holscher Design



Selected
ADI DESIGN INDEX
2023 – Leva
Design by Park
2023 – Vertical system
Design by Dnd
2019 – (IN)finito
Design by Alfonso Femia

PROGETTISTI / DESIGNERS

La collaborazione con i designer è parte fondamentale del processo produttivo e creativo di Dnd. Con continuità e attenzione, l'azienda coinvolge progettisti italiani e internazionali di grande talento, esponenti del miglior mondo del progetto. Voci tra loro differenti per stile e approccio, che hanno contribuito a generare un catalogo molto articolato di oggetti che spiccano per disegno e realizzazione.

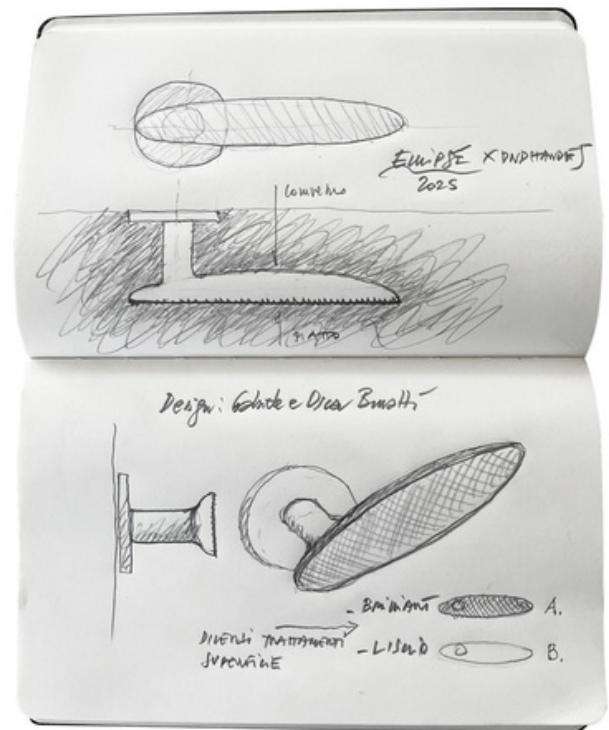
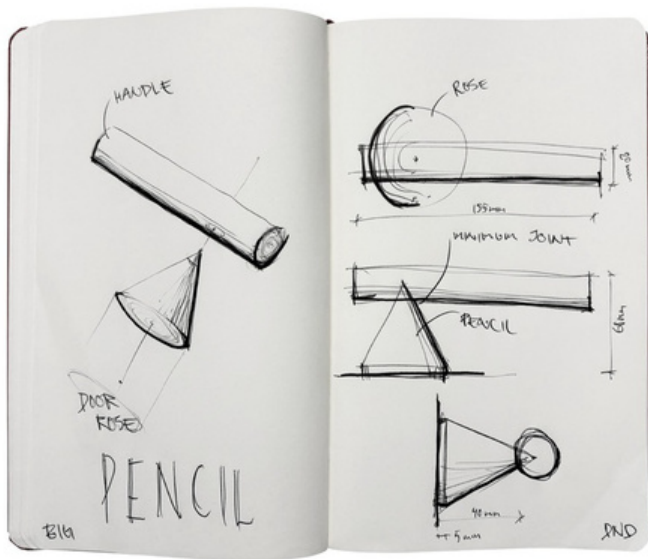

Collaborating with designers is a fundamental part of Dnd's manufacturing and creative process. The company continuously and painstakingly works alongside highly talented Italian and international designers, who epitomise the best in the world of design. By dint of these designers' individual styles and approaches, Dnd is proud to offer an ultra-detailed range of products that stand out as far as design and production are concerned.



967arch



BIG - Bjarke
Ingels Group



Stefano Boeri
Architetti



Gabriele &
Oscar Buratti



Achille
Castiglioni



Gianfranco
Cavaglià



Alfonso
Femia



Odo
Fioravanti



Alessandro
Gnocchi



Jaime
Hayon



Holscher
Design



Studio
Hot Lab



Giulio
Iacchetti



Enrico
Mar tini



Andrea
Morgante



Luca
Nichetto



Nicola
Novelletto



Mario
Padiglione



Park



Marco
Pisati



Karim
Rashid



Mauro
Ronchi



Elena
Salmistraro



Sandro
Santantonio



Mario Scairato &
Alessandro Stabile



Didier
Schweizer



Inga
Sempé



Philippe
Tabet



Maurizio
Varratta



Cino
Zucchi

REALIZZAZIONI / PROJECTS

Le maniglie Dnd vengono scelte per valorizzare interni domestici e pubblici, in tutto il mondo. Inoltre, l'azienda offre una consulenza diretta ad architetti e designer per selezionare al meglio prodotti e finiture e valutare insieme soluzioni personalizzate. Dalle positive relazioni di scambio con i progettisti e i costruttori degli ambienti architettonici nascono racconti interessanti: Dnd è felice di condividere immagini e pensieri relativi a questi progetti di interni, frutto di impegno e creatività.

Dnd handles have been chosen to enhance both domestic and public interiors, all over the world. Furthermore, the company offers direct consultancy to architects and designers to best select the products and finishes, and identify custom solutions together. Interesting stories have arisen from these positive exchanges with the designers and builders of architectural environments: Dnd is proud to share images and feedback received regarding these interior projects, which are the result of hard work and creativity.

Clinica Baviera
Oviedo, ES



Royale Belge
Bruxelles, BE



Isozaki Tower
Milano, IT

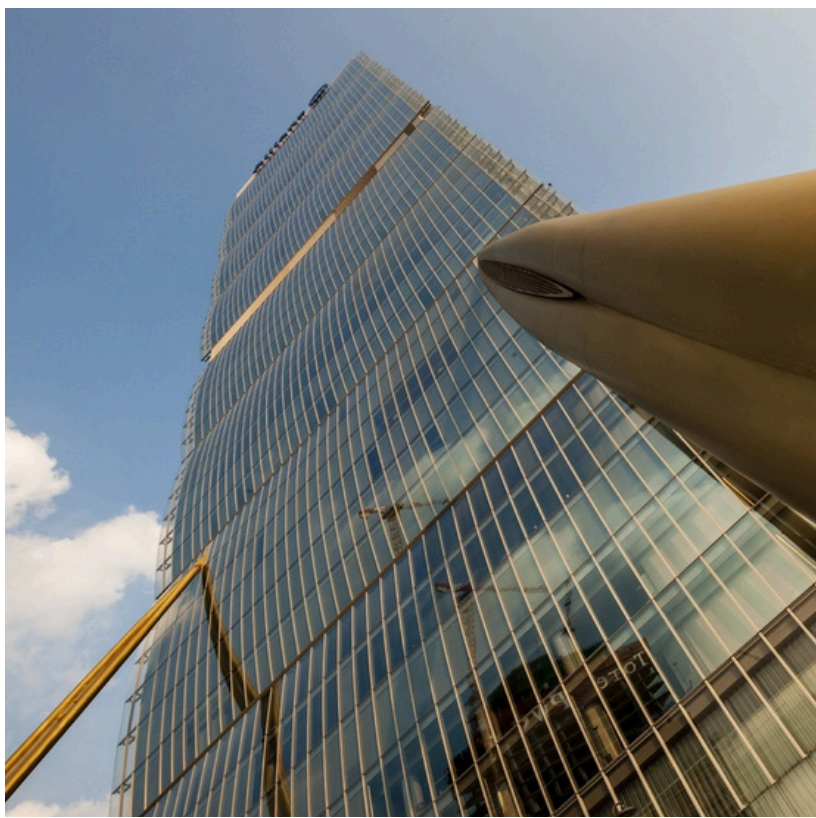



Unica restaurant
Sofia, BG



**Uffici Studio Inzaghi
di Torre Velasca**
Milano, IT

Realizzazioni internazionali
con maniglie Dnd
International projects
with Dnd handles





Renocon Design Center
Vancouver, CA



Posco Tower
New Songdo, KR



Londonderry,
Italian Luxury Group
Los Angeles, US

SISTEMI PER PORTE E FINESTRE

DOOR AND WINDOW SYSTEMS

dnd/total look®

Il total look tra maniglia e serratura rappresenta un approccio innovativo al design della porta, in cui ogni elemento dialoga armoniosamente per creare un'estetica coordinata e funzionale. Questa visione si basa sull'integrazione stilistica e cromatica, dove maniglia e serratura diventano protagonisti di un progetto unico, capace di esaltare il carattere dell'ambiente. Non si tratta solo di dettagli tecnici, ma di una scelta che unisce eleganza e praticità, trasformando la porta in un vero e proprio elemento d'arredo.

The total look between handle and lock represents an innovative approach to door design, in which each element dialogues harmoniously to create a coordinated and functional aesthetic. This vision is based on stylistic and chromatic integration, where handle and lock become the protagonists of a unique design, capable of enhancing the character of the environment. These are not just technical details, but a choice that combines elegance and practicality, transforming the door into a true piece of furniture.



Consulta la brochure
View the brochure
dndtotal look



VERTICAL

SISTEMA DI CHIUSURA PER PORTE INTERNE

LOCKING SYSTEM FOR INTERIOR DOORS

Vertical è il sistema di chiusura con serratura invisibile per porte interne: consente una perfetta apertura e chiusura dell'anta, assicura prestazioni sul lungo periodo, ha un valore estetico che incontra le tendenze dell'interior design contemporaneo.

Con il sistema Vertical, Dnd fornisce un kit porta completo e coordinato con tutte le maniglie di design a catalogo.

Vertical is the locking system with an invisible lock for interior doors: it allows perfect opening and closing of the door, ensures long-term performance, has an aesthetic value that meets the trends contemporary interior design trends.

With the Vertical system, Dnd provides a complete and coordinated door kit with all the design handles in the catalogue.

PATENTED



Guarda il video
Watch the video
Vertical



 **ADI
DESIGN
INDEX**
Selezione Compasso d'Oro



Certificazione EN 12209:2024

La serratura Vertical di Dnd è certificata secondo la norma EN 12209:2024, a garanzia di qualità, sicurezza e affidabilità. Questa certificazione attesta che il prodotto soddisfa i più rigorosi standard europei per serrature, coprendo requisiti di funzionalità, durata, resistenza meccanica e sicurezza.

Certification EN 12209:2024 Dnd's Vertical lock is certified according to the EN 12209:2024 standard, ensuring quality, safety, and reliability. This certification confirms that the product meets the strictest European standards for locks, covering requirements for functionality, durability, mechanical strength, and security.

Classificazione Classification

1	C	7	0	0	D	0	-
---	---	---	---	---	---	---	---

ICIM

**Certificazione di Prodotto
Product Certification**

Certificato N. / Certificate No. **ICIM-SRM - 0001 55-00**
TO THE FIRM

DND Martinelli S.r.l.
Via Piani di Mura, 2,
25070 Casto (BS) - IT

UNITA OPERATIVE / OPERATIVES UNITS
Via Piani di Mura, 2,
25070 Casto (BS) - IT

PER I SEGUENTI PRODOTTI / FOR THE FOLLOWING PRODUCTS
**SERRATURE AZIONATE MECCANICAMENTE
MECHANICALLY OPERATED LOCKS**

CON DENOMINAZIONE COMMERCIALE / WITH TRADE NAME /
Brand: **DND**

Serie: **DND Vertical**

Modelli: Vedi tabella in allegato
Models: See annex table

Classificazione / Classification: **ICIM 0059CS**

CONFORMEMENTE ALLA NORMA / IN COMPLIANCE WITH THE STANDARDS
EN 12209:2024 / UNI EN 12209:2025

Il presente Certificato è d'attinenza valida solo se accompagnata dal relativo Allegato / This Certificate is valid only with the relative Annex

Vincenzo De Luca
Rappresentante / Representative

ICIM S.p.A.

PRIMA EMISSIONE FIRST ISSUE 19/01/2026	EMISSIONE CORRENTE CURRENT ISSUE 19/01/2026	DATA DI SCADENZA EXPIRING DATE 18/01/2029
--	---	---

ICIM S.p.A. - Piazza Don Enrico Maselli, 75 - 38069 Sesto San Giovanni (BS)
Servizio supportato all'attività di emissione e mantenimento di ICIM S.p.A.

ICIM

**Certificazione di Prodotto
Product Certification**

ALLEGATO AL / ANNEX TO
Certificato N. / Certificate No. **ICIM-SRM - 0001 55-00**

Caratteristiche / Characteristics: Classificazione EN 12209:2024 / UNI EN 12209:2025 in ICIM 0059CS EN 12209:2024 / UNI EN 12209:2025 in ICIM 0059CS Classification	
Modello / Model: VRTLVRTLKVRTLN	Classificazione / Classification
Accessori / Accessories: INC1	1 C 7 0 0 D 0 -

Serratura a chiave solo con fallazzo con il proprio incastro fornito in kit e installato secondo le istruzioni del fabbricante
Lock suitable only for use with its own strike supplied in a kit and installed according to the manufacturer's instructions.

Vincenzo De Luca
Rappresentante / Representative

ICIM S.p.A.

PRIMA EMISSIONE FIRST ISSUE 19/01/2026	EMISSIONE CORRENTE CURRENT ISSUE 19/01/2026	DATA DI SCADENZA EXPIRING DATE 18/01/2029
--	---	---

ICIM S.p.A. - Piazza Don Enrico Maselli, 75 - 38069 Sesto San Giovanni (BS)
Servizio supportato all'attività di emissione e mantenimento di ICIM S.p.A.



TIMELESS + VERTICAL
ARO

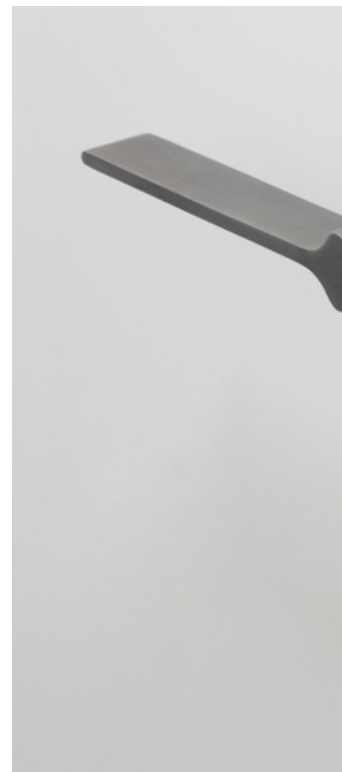

GINKGO + VERTICAL
PGS for te®



DUE + VERTICAL
PVD-SB for te®



IKI + VERTICAL
ZCS



ANIK + VERTICAL
ONO



Consulta la brochure
View the brochure
opening your projects

FORO CC / CC HOLE

Un dettaglio destinato a ridefinire estetica e funzionalità, aprendo nuove prospettive per il mondo del design e dei sistemi di chiusura. Il foro CC (o foro Click & Close) è il nuovo foro tondo da Ø 9 mm applicato alle bocchette delle maniglie e progettato per ospitare nuove tipologie di chiavi. Abbinabile a serrature con quadro da 6 mm, la soluzione introduce un nuovo standard superando il tradizionale foro patent su bocchette e serrature.

A detail designed to redefine aesthetics and functionality, opening up new perspectives for the world of design and locking systems. The CC hole (or Click & Close hole) is the new Ø 9 mm round hole applied to handle escutcheons, designed to accommodate new types of keys. Compatible with locks featuring a 6 mm spindle, this solution introduces a new standard, moving beyond the traditional patent hole on both escutcheons and locks.





CLICK & CLOSE

PATENT PENDING

Click & Close supera il concetto di chiave tradizionale per esaltare l'estetica integrata con la maniglia, si connette alla bocchetta per attrazione magnetica e si incorpora perfettamente, generando un elemento unico, armonico e solido. La chiave, con \varnothing 6 mm, da semplice strumento funzionale, diventa un oggetto che riflette design, eleganza e innovazione.

Click & Close goes beyond the concept of the traditional key to enhance an aesthetic fully integrated with the handle. It connects to the escutcheon through magnetic attraction and fits seamlessly into it, creating a single, harmonious, and solid element. The key, with \varnothing 6 mm, once a purely functional tool, becomes an object that reflects design, elegance, and innovation.



Consulta la brochure
View the brochure
Click & Close

DND KEY PLUS NEW

DESIGN: GIULIO IACCHETTI

Semplice nell'utilizzo, curata nei dettagli, Dnd key plus non è solo una chiave funzionale, ma un elemento di design che completa il progetto, esaltando la finitura grazie all'elemento circolare pulito e perfettamente coordinato con la finitura della maniglia contribuendo a un risultato finale coerente, elegante e attuale. Una nuova interpretazione della chiave, con \varnothing 6 mm, pensata per dialogare in modo naturale con il foro CC delle bocchette.

Simple to use and refined in every detail, Dnd key plus is not just a functional key, but a design element that completes the project, enhancing the finish through its clean circular element, perfectly coordinated with the handle's finish, and contributing to a coherent, elegant, and contemporary final result. A new interpretation of the key, with \varnothing 6 mm, designed to naturally interact with the CC escutcheon hole.

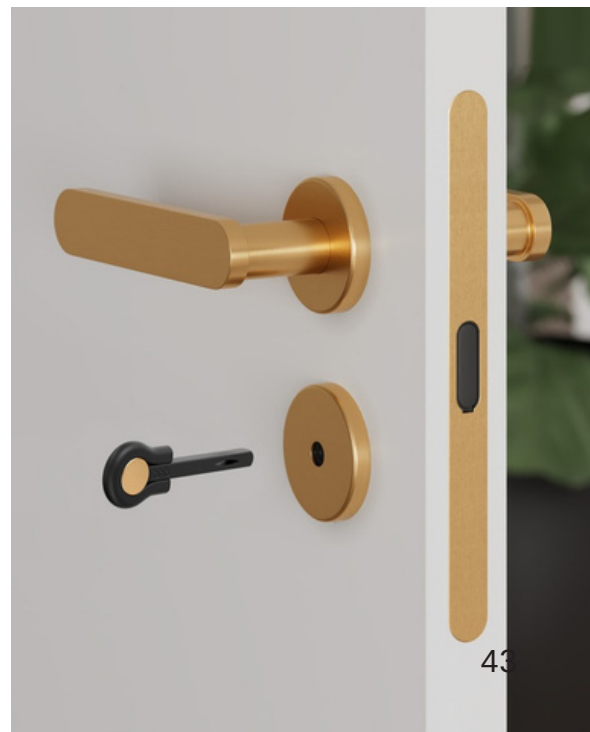

VERSO

SISTEMA DI CHIUSURA PER PORTE SCORREVOLI

LOCKING SYSTEM FOR SLIDING DOORS

Verso è il sistema di serrature per porte scorrevoli compatto e dalle alte prestazioni con cover in ottone per uniformare i colori degli elementi metallici. Disponibile nella versione con foro cilindro Yale o quadro da 8 mm permette un'estetica contemporanea, minimale ed elegante, garantita dalla totale assenza di viti sul frontale e dalla possibilità di utilizzare le medesime finiture delle maniglie Dnd per porte scorrevoli sulla cover della serratura.

Verso is a high-performance locking system for sliding doors with brass covers to match the colours of the metal elements. Available in versions with a Yale cylinder hole or 8 mm square hole, it offers a contemporary, minimalist and elegant look, guaranteed by the total absence of screws on the front and the possibility of using the same finishes as the Dnd handles for sliding doors on the lock cover.



Scheda prodotto
Product data sheet
Verso



RESISTENZA AL FUOCO FIRE RESISTANCE



Attestati di resistenza al fuoco EN 1634-2 ED. 2008

Test di resistenza al fuoco e al fumo per porte, finestre, serrature e componenti di ferramenta da costruzione.

I prodotti Dnd possono essere utilizzati per installazioni su porte e finestre che hanno ottenuto la certificazione EN 1634-2 e che hanno dimostrato di possedere la medesima resistenza al fuoco.

Attestation of fire resistance EN 1634-2 ED. 2008

Fire resistance and smoke control tests for door, shutter and openable window assemblies and elements of building hardware. The Dnd products can be used for installation on doors and openable windows of similar type that had been tested according to EN 1634-2, and have been shown to have at last the same fire resistance.



LAPI LABORATORIO PREVENZIONE INCENDI S.p.A.
 Strada Provinciale 3 51-06 PRATO - Via della Quercia, 11
 Telefono +39 0574 571 100 - Telefax +39 0574 571 123
 Sede Secondaria - 51004 CALENZANO (PD) Via Valsugana, 48
 e-mail: lapi@lapi.it o www.lapi.it
 web site: www.laboratorioincendi.it

ATTESTAZIONE DI RESISTENZA AL FUOCO
ATTESTATION OF FIRE RESISTANCE
 REV.01 of 05/04/2024

PRODUTTORE / PRODUCER:
DND MARTINELLI S.r.l.
 Loc. Piani di Murà, 2
 25070 Casto (BS)



STANDARD DI RIFERIMENTO / REFERENCE STANDARD:
 EN 1634-2 Ed. 2008

Prove di resistenza al fuoco e di controllo della dispersione del fumo per porte, sistemi di chiusura, finestre apribili e loro componenti costituenti - Parte 2: Prove di resistenza per componenti costituenti

Fire resistance and smoke control tests for door, shutter and openable window assemblies and elements of building hardware

Part 2: Fire resistance characterisation test for elements of building hardware

Sulla base del test eseguito, la durata di resistenza al fuoco della maniglia

On the base of the test performed, the fire resistance duration of the door handle

ARETE', ARIONE, APPA, ARETE' L ART, BEVERLY, BIANDI, BOOLE, BRUXELLES, C19A, CHANGE B, CLASSIC, CLASSIC 2, CLOE', DANIELA, DOLCE, DRAP, DUE, EDRA, FIDORA, FIORE, FIORENZA, FLORE, FLORE 2, FLORE', GINISIO, GINISIO BLOCCA, GIGI, GIGI FRENTO, INTAKE, ISABELLA, LADY, LATRAL, LEVA, LEVANTE, LINEAR, LINEAR, LONINA, LUCREZIA, LUXURY, MADELINE, MOVIDA, NICE, PROJECT, SAG, SAG ISO, SAFETY, SHIRT, SKE, SKE 2, TWIST, TWIST 2, ZEPPELIN

8 / 10

Integrità/Integrity: 68 minutes
Isolamento/Insulation: 68 minutes

I risultati di prova si riferiscono solo ai prodotti fabbricati e installati in conformità con i campioni testati e descritti nei rapporti di prova N° 2492-2493-2494-2495-2496-2497-2498-2499-2500-2501-2502-2503-2504-2505-2506-2507-2508-2509-2510-2511-2512-2513-2514-2515-2516-2517-2518-2519-2520-2521-2522-2523-2524-2525-2526-2527-2528-2529-2530-2531-2532-2533-2534-2535-2536-2537-2538-2539-2540-2541-2542-2543-2544-2545-2546-2547-2548-2549-2550-2551-2552-2553-2554-2555-2556-2557-2558-2559-2560-2561-2562-2563-2564-2565-2566-2567-2568-2569-2570-2571-2572-2573-2574-2575-2576-2577-2578-2579-2580-2581-2582-2583-2584-2585-2586-2587-2588-2589-2590-2591-2592-2593-2594-2595-2596-2597-2598-2599-2600-2601-2602-2603-2604-2605-2606-2607-2608-2609-2610-2611-2612-2613-2614-2615-2616-2617-2618-2619-2620-2621-2622-2623-2624-2625-2626-2627-2628-2629-2630-2631-2632-2633-2634-2635-2636-2637-2638-2639-2640-2641-2642-2643-2644-2645-2646-2647-2648-2649-2650-2651-2652-2653-2654-2655-2656-2657-2658-2659-2660-2661-2662-2663-2664-2665-2666-2667-2668-2669-2670-2671-2672-2673-2674-2675-2676-2677-2678-2679-2680-2681-2682-2683-2684-2685-2686-2687-2688-2689-2690-2691-2692-2693-2694-2695-2696-2697-2698-2699-2700-2701-2702-2703-2704-2705-2706-2707-2708-2709-2710-2711-2712-2713-2714-2715-2716-2717-2718-2719-2720-2721-2722-2723-2724-2725-2726-2727-2728-2729-2730-2731-2732-2733-2734-2735-2736-2737-2738-2739-2740-2741-2742-2743-2744-2745-2746-2747-2748-2749-2750-2751-2752-2753-2754-2755-2756-2757-2758-2759-2760-2761-2762-2763-2764-2765-2766-2767-2768-2769-2770-2771-2772-2773-2774-2775-2776-2777-2778-2779-2780-2781-2782-2783-2784-2785-2786-2787-2788-2789-2790-2791-2792-2793-2794-2795-2796-2797-2798-2799-2800-2801-2802-2803-2804-2805-2806-2807-2808-2809-2810-2811-2812-2813-2814-2815-2816-2817-2818-2819-2820-2821-2822-2823-2824-2825-2826-2827-2828-2829-2830-2831-2832-2833-2834-2835-2836-2837-2838-2839-2840-2841-2842-2843-2844-2845-2846-2847-2848-2849-2850-2851-2852-2853-2854-2855-2856-2857-2858-2859-2860-2861-2862-2863-2864-2865-2866-2867-2868-2869-2870-2871-2872-2873-2874-2875-2876-2877-2878-2879-2880-2881-2882-2883-2884-2885-2886-2887-2888-2889-2890-2891-2892-2893-2894-2895-2896-2897-2898-2899-2900-2901-2902-2903-2904-2905-2906-2907-2908-2909-2910-2911-2912-2913-2914-2915-2916-2917-2918-2919-2920-2921-2922-2923-2924-2925-2926-2927-2928-2929-2930-2931-2932-2933-2934-2935-2936-2937-2938-2939-2940-2941-2942-2943-2944-2945-2946-2947-2948-2949-2950-2951-2952-2953-2954-2955-2956-2957-2958-2959-2960-2961-2962-2963-2964-2965-2966-2967-2968-2969-2970-2971-2972-2973-2974-2975-2976-2977-2978-2979-2980-2981-2982-2983-2984-2985-2986-2987-2988-2989-2990-2991-2992-2993-2994-2995-2996-2997-2998-2999-3000-3001-3002-3003-3004-3005-3006-3007-3008-3009-3010-3011-3012-3013-3014-3015-3016-3017-3018-3019-3020-3021-3022-3023-3024-3025-3026-3027-3028-3029-3030-3031-3032-3033-3034-3035-3036-3037-3038-3039-3040-3041-3042-3043-3044-3045-3046-3047-3048-3049-3050-3051-3052-3053-3054-3055-3056-3057-3058-3059-3060-3061-3062-3063-3064-3065-3066-3067-3068-3069-3070-3071-3072-3073-3074-3075-3076-3077-3078-3079-3080-3081-3082-3083-3084-3085-3086-3087-3088-3089-3090-3091-3092-3093-3094-3095-3096-3097-3098-3099-3100-3101-3102-3103-3104-3105-3106-3107-3108-3109-3110-3111-3112-3113-3114-3115-3116-3117-3118-3119-3120-3121-3122-3123-3124-3125-3126-3127-3128-3129-3130-3131-3132-3133-3134-3135-3136-3137-3138-3139-3140-3141-3142-3143-3144-3145-3146-3147-3148-3149-3150-3151-3152-3153-3154-3155-3156-3157-3158-3159-3160-3161-3162-3163-3164-3165-3166-3167-3168-3169-3170-3171-3172-3173-3174-3175-3176-3177-3178-3179-3180-3181-3182-3183-3184-3185-3186-3187-3188-3189-3190-3191-3192-3193-3194-3195-3196-3197-3198-3199-3200-3201-3202-3203-3204-3205-3206-3207-3208-3209-3210-3211-3212-3213-3214-3215-3216-3217-3218-3219-3220-3221-3222-3223-3224-3225-3226-3227-3228-3229-3230-3231-3232-3233-3234-3235-3236-3237-3238-3239-3240-3241-3242-3243-3244-3245-3246-3247-3248-3249-3250-3251-3252-3253-3254-3255-3256-3257-3258-3259-3260-3261-3262-3263-3264-3265-3266-3267-3268-3269-3270-3271-3272-3273-3274-3275-3276-3277-3278-3279-3280-3281-3282-3283-3284-3285-3286-3287-3288-3289-3290-3291-3292-3293-3294-3295-3296-3297-3298-3299-3300-3301-3302-3303-3304-3305-3306-3307-3308-3309-3310-3311-3312-3313-3314-3315-3316-3317-3318-3319-3320-3321-3322-3323-3324-3325-3326-3327-3328-3329-3330-3331-3332-3333-3334-3335-3336-3337-3338-3339-3340-3341-3342-3343-3344-3345-3346-3347-3348-3349-3350-3351-3352-3353-3354-3355-3356-3357-3358-3359-3360-3361-3362-3363-3364-3365-3366-3367-3368-3369-3370-3371-3372-3373-3374-3375-3376-3377-3378-3379-3380-3381-3382-3383-3384-3385-3386-3387-3388-3389-3390-3391-3392-3393-3394-3395-3396-3397-3398-3399-3400-3401-3402-3403-3404-3405-3406-3407-3408-3409-3410-3411-3412-3413-3414-3415-3416-3417-3418-3419-3420-3421-3422-3423-3424-3425-3426-3427-3428-3429-3430-3431-3432-3433-3434-3435-3436-3437-3438-3439-3440-3441-3442-3443-3444-3445-3446-3447-3448-3449-3450-3451-3452-3453-3454-3455-3456-3457-3458-3459-3460-3461-3462-3463-3464-3465-3466-3467-3468-3469-3470-3471-3472-3473-3474-3475-3476-3477-3478-3479-3480-3481-3482-3483-3484-3485-3486-3487-3488-3489-3490-3491-3492-3493-3494-3495-3496-3497-3498-3499-3500-3501-3502-3503-3504-3505-3506-3507-3508-3509-3510-3511-3512-3513-3514-3515-3516-3517-3518-3519-3520-3521-3522-3523-3524-3525-3526-3527-3528-3529-3530-3531-3532-3533-3534-3535-3536-3537-3538-3539-3540-3541-3542-3543-3544-3545-3546-3547-3548-3549-3550-3551-3552-3553-3554-3555-3556-3557-3558-3559-3560-3561-3562-3563-3564-3565-3566-3567-3568-3569-3570-3571-3572-3573-3574-3575-3576-3577-3578-3579-3580-3581-3582-3583-3584-3585-3586-3587-3588-3589-3590-3591-3592-3593-3594-3595-3596-3597-3598-3599-3600-3601-3602-3603-3604-3605-3606-3607-3608-3609-3610-3611-3612-3613-3614-3615-3616-3617-3618-3619-3620-3621-3622-3623-3624-3625-3626-3627-3628-3629-3630-3631-3632-3633-3634-3635-3636-3637-3638-3639-3640-3641-3642-3643-3644-3645-3646-3647-3648-3649-3650-3651-3652-3653-3654-3655-3656-3657-3658-3659-3660-3661-3662-3663-3664-3665-3666-3667-3668-3669-3670-3671-3672-3673-3674-3675-3676-3677-3678-3679-3680-3681-3682-3683-3684-3685-3686-3687-3688-3689-3690-3691-3692-3693-3694-3695-3696-3697-3698-3699-3700-3701-3702-3703-3704-3705-3706-3707-3708-3709-3710-3711-3712-3713-3714-3715-3716-3717-3718-3719-3720-3721-3722-3723-3724-3725-3726-3727-3728-3729-3730-3731-3732-3733-3734-3735-3736-3737-3738-3739-3740-3741-3742-3743-3744-3745-3746-3747-3748-3749-3750-3751-3752-3753-3754-3755-3756-3757-3758-3759-3760-3761-3762-3763-3764-3765-3766-3767-3768-3769-3770-3771-3772-3773-3774-3775-3776-3777-3778-3779-3780-3781-3782-3783-3784-3785-3786-3787-3788-3789-3790-3791-3792-3793-3794-3795-3796-3797-3798-3799-3800-3801-3802-3803-3804-3805-3806-3807-3808-3809-3810-3811-3812-3813-3814-3815-3816-3817-3818-3819-3820-3821-3822-3823-3824-3825-3826-3827-3828-3829-3830-3831-3832-3833-3834-3835-3836-3837-3838-3839-3840-3841-3842-3843-3844-3845-3846-3847-3848-3849-3850-3851-3852-3853-3854-3855-3856-3857-3858-3859-3860-3861-3862-3863-3864-3865-3866-3867-3868-3869-3870-3871-3872-3873-3874-3875-3876-3877-3878-3879-3880-3881-3882-3883-3884-3885-3886-3887-3888-3889-3890-3891-3892-3893-3894-3895-3896-3897-3898-3899-3900-3901-3902-3903-3904-3905-3906-3907-3908-3909-3910-3911-3912-3913-3914-3915-3916-3917-3918-3919-3920-3921-3922-3923-3924-3925-3926-3927-3928-3929-3930-3931-3932-3933-3934-3935-3936-3937-3938-3939-3940-3941-3942-3943-3944-3945-3946-3947-3948-3949-3950-3951-3952-3953-3954-3955-3956-3957-3958-3959-3960-3961-3962-3963-3964-3965-3966-3967-3968-3969-3970-3971-3972-3973-3974-3975-3976-3977-3978-3979-3980-3981-3982-3983-3984-3985-3986-3987-3988-3989-3990-3991-3992-3993-3994-3995-3996-3997-3998-3999-4000-4001-4002-4003-4004-4005-4006-4007-4008-4009-4010-4011-4012-4013-4014-4015-4016-4017-4018-4019-4020-4021-4022-4023-4024-4025-4026-4027-4028-4029-4030-4031-4032-4033-4034-4035-4036-4037-4038-4039-4040-4041-4042-4043-4044-4045-4046-4047-4048-4049-4050-4051-4052-4053-4054-4055-4056-4057-4058-4059-4060-4061-4062-4063-4064-4065-4066-4067-4068-4069-4070-4071-4072-4073-4074-4075-4076-4077-4078-4079-4080-4081-4082-4083-4084-4085-4086-4087-4088-4089-4090-4091-4092-4093-4094-4095-4096-4097-4098-4099-4100-4101-4102-4103-4104-4105-4106-4107-4108-4109-4110-4111-4112-4113-4114-4115-4116-4117-4118-4119-4120-4121-4122-4123-4124-4125-4126-4127-4128-4129-4130-4131-4132-4133-4134-4135-4136-4137-4138-4139-4140-4141-4142-4143-4144-4145-4146-4147-4148-4149-4150-4151-4152-4153-4154-4155-4156-4157-4158-4159-4160-4161-4162-4163-4164-4165-4166-4167-4168-4169-4170-4171-4172-4173-4174-4175-4176-4177-4178-4179-4180-4181-4182-4183-4184-4185-4186-4187-4188-4189-4190-4191-4192-4193-4194-4195-4196-4197-4198-4199-4200-4201-4202-4203-4204-4205-4206-4207-4208-4209-4210-4211-4212-4213-4214-4215-4216-4217-4218-4219-4220-4221-4222-4223-4224-4225-4226-4227-4228-4229-4230-4231-4232-4233-4234-4235-4236-4237-4238-4239-4240-4241-4242-4243-4244-4245-4246-4247-4248-4249-4250-4251-4252-4253-4254-4255-4256-4257-4258-4259-4260-4261-4262-4263-4264-4265-4266-4267-4268-4269-4270-4271-4272-4273-4274-4275-4276-4277-4278-4279-4280-4281-4282-4283-4284-4285-4286-4287-4288-4289-4290-4291-4292-4293-4294-4295-4296-4297-4298-4299-4300-4301-4302-4303-4304-4305-4306-4307-4308-4309-4310-4311-4312-4313-4314-4315-4316-4317-4318-4319-4320-4321-4322-4323-4324-4325-4326-4327-4328-4329-4330-4331-4332-4333-4334-4335-4336-4337-4338-4339-4340-4341-4342-4343-4344-4345-4346-4347-4348-4349-4350-4351-4352-4353-4354-4355-4356-4357-4358-4359-4360-4361-4362-4363-4364-4365-4366-4367-4368-4369-4370-4371-4372-4373-4374-4375-4376-4377-4378-4379-4380-4381-4382-4383-4384-4385-4386-4387-4388-4389-4390-4391-4392-4393-4394-4395-4396-4397-4398-4399-4400-4401-4402-4403-4404-4405-4406-4407-4408-4409-4410-4411-4412-4413-4414-4415-4416-4417-4418-4419-4420-4421-4422-4423-4424-4425-4426-4427-4428-4429-4430-4431-4432-4433-4434-4435-4436-4437-4438-4439-4440-4441-4442-4443-4444-4445-4446-4447-4448-4449-4450-4451-4452-4453-4454-4455-4456-4457-4458-4459-4460-4461-4462-4463-4464-4465-4466-4467-4468-4469-4470-4471-4472-4473-4474-4475-4476-4477-4478-4479-4480-4481-4482-4483-4484-4485-4486-4487-4488-4489-4490-4491-4492-4493-4494-4495-4496-4497-4498-4499-4500-4501-4502-4503-4504-4505-4506-4507-4508-4509-4510-4511-4512-4513-4514-4515-4516-4517-4518-4519-4520-4521-4522-4523-4524-4525-4526-4527-4528-4529-4530-4531-4532-4533-4534-4535-4536-4537-4538-4539-4540-4541-4542-4543-4544-4545-4546-4547-4548-4549-4550-4551-4552-4553-4554-4555-4556-4557-4558-4559-4560-4561-4562-4563-4564-4565-4566-4567-4568-4569-4570-4571-4572-4573-4574-4575-4576-4577-4578-4579-4580-4581-4582-4583-4584-4585-4586-4587-4588-4589-4590-4591-4592-4593-4594-4595-4596-4597-4598-4599-4600-4601-4602-4603-4604-4605-4606-4607-4608-4609-4610-4611-4612-4613-4614-4615-4616-4617-4618-4619-4620-4621-4622-4623-4624-4625-4626-4627-4628-4629-4630-4631-4632-4633-4634-4635-4636-4637-4638-4639-4640-4641-4642-4643-4644-4645-4646-4647-4648-4649-4650-4651-4652-4653-4654-4655-4656-4657-4658-4659-4660-4661-4662-4663-4664-4665-4666-4667-4668-4669-4670-4671-4672-4673-4674-4675-4676-4677-4678-4679-4680-

SIMBOLI / SYMBOLS

PORTA DOOR

- VIS** **50x7 mm**
rosetta-bocchetta tonda
round rose-escutcheon
- FINE** **50x4 mm**
rosetta-bocchetta tonda
round rose-escutcheon
- 52** **52x12 mm**
rosetta-bocchetta tonda
round rose-escutcheon
- B** **50x10 mm**
rosetta-bocchetta tonda bombata
rounded rose-escutcheon
- R** **rosetta-bocchetta speciale**
special rose-escutcheon
- S** **31x62x9,5 mm**
rosetta-bocchetta stretta ovale
narrow oval rose-escutcheon
- U** **30x2 mm**
rosetta minimal Unico
minimal Unico rose
- U** **25x2 mm**
bocchetta minimal Unico
minimal Unico escutcheon
- VIS** **50x7 mm**
rosetta-bocchetta quadra
square rose-escutcheon
- FINE** **50x4 mm**
rosetta-bocchetta quadra
square rose-escutcheon
- 45** **45x10 mm**
rosetta-bocchetta quadra
square rose-escutcheon
- 52** **52x12 mm**
rosetta-bocchetta quadra
square rose-escutcheon
- R** **52x12 mm**
rosetta-bocchetta quadra
square rose-escutcheon
- S** **rosetta-bocchetta speciale quadra**
special square rose-escutcheon
- S** **31x62x9,5 mm**
rosetta-bocchetta stretta rettangolare stondata
rounded rectangular narrow rose-escutcheon
- S** **31x62x9,5 mm**
rosetta-bocchetta stretta rettangolare a spigolo
corner rectangular narrow rose-escutcheon

FINESTRA WINDOW

- VIS** **31x64x9 mm**
rosetta ovale per DK VIS
DK VIS oval rose
- 31x64x9 mm**
U **rosetta ovale per DK VIS TS - sicurezza**
DK VIS TS oval rose for security latch
- 34x10 mm**
U **rosetta minimal Unico per DK**
DK minimal Unico rose
- VIS** **31x64x9 mm**
rosetta rettangolare per DK VIS
DK VIS rectangular rose
- 31x64x9 mm**
U **rosetta rettangolare per DK VIS TS - sicurezza**
DK VIS TS rectangular rose for security latch
- R** **31x64x12 mm**
rosetta Dnd rettangolare pesante per DK
Dnd rectangular heavy rose for DK

A RICHIESTA ON DEMAND

ON DEMAND

modelli di prodotti e finiture disponibili su richiesta,
previa valutazione dei quantitativi e approvazione da
parte dell'azienda
product models and finishes available upon request,
subject to evaluation of quantities and approval by
the company

IL SISTEMA UNICO / UNICO, THE SYSTEM



minimal,
elegant,
Unico

SAN
ZNE

Unico è il sistema per porte – ideato da Dnd – che riduce al minimo l'impatto visivo della rosetta sulla maniglia, valorizzandone così il design: una soluzione tecnica ed estetica ideale per gli ambienti contemporanei.

Grazie al suo piccolo volume, risulta poco visibile: misura solo 30 mm di diametro e 2 mm di spessore. Il sistema, proposto in forma rotonda, è facile da installare e prevede la realizzazione di un foro da 22 mm sulla porta.

Unico is the system for doors – designed by Dnd – that minimises the visual impact of the rose on the handle, thus enhancing its design: a technical and aesthetic solution that is ideal for contemporary interiors.

Thanks to its small volume, it is hardly visible: it measures only 30 mm in diameter and 2 mm in thickness. The system, which comes in a round shape, is easy to install and requires a 22 mm hole to be drilled in the door.



LEVA
PVN | forte®



VIVA!
PVD-BG | forte®



LUCE P
ZCS



SHORT
PGS | forte®



Sistema Unico disponibile
per 37 modelli in tutte le loro finiture
Unico System available
on 37 models in all their finishes

nottolino e bocchette
turn & release and escutcheons



241 3+A



BD80Y



BD80P



SHORT
PGS | forte®

SISTEMA UNICO DISPONIBILE ANCHE PER FINESTRE

UNICO SYSTEM AVAILABLE ALSO FOR WINDOWS

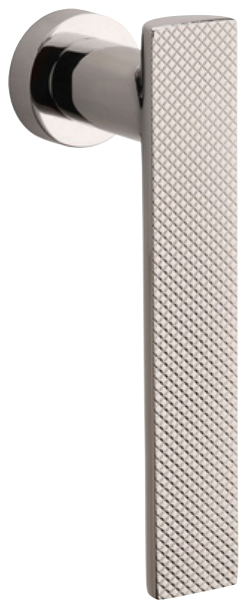

ANIK BRILLIANT
PVN | forte®

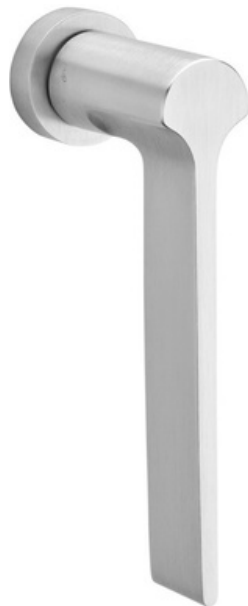

GINKGO
OCS



LEVA
PGS | forte®



LUCE P
ZNE

Il sistema Unico è disponibile anche per serramenti, su cui la discrezione della rosetta – di soli 34 mm di diametro e 10 mm di spessore – esalta pienamente la forma e il disegno della maniglia. Sistema DK a 8 scatti, facile da installare con la realizzazione di un foro da 13 mm sul serramento.

The Unico system is also available for windows, where the discretion of the rose – just 34 mm in diameter and 10 mm in thickness – fully enhances the shape and design of the handle. DK 8 position-system, easy to install by drilling a 13 mm hole in the frame.

SISTEMA LESS IS FINE 4 MM LESS IS FINE SYSTEM 4 MM

FINE

FINE

PORTADOOR

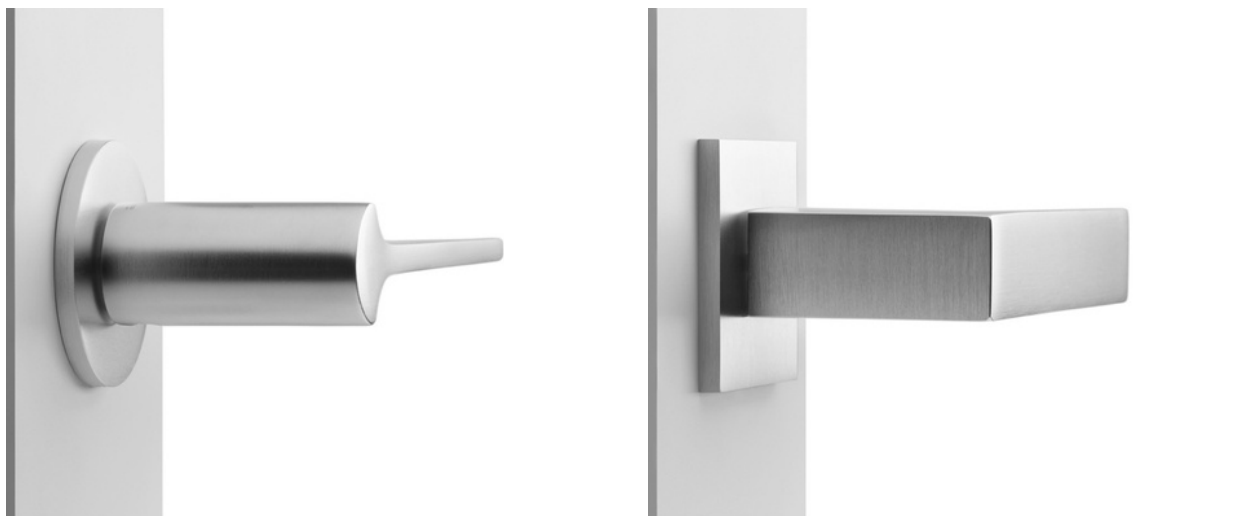

Il nuovo meccanismo per maniglie Dnd è completamente realizzato in metallo e sostituisce il vecchio rotore in plastica e le due molle a compressione con una innovativa molla a torsione a sezione quadrata. La stessa adottata nel sistema VIS: è quindi possibile ritrovare la medesima sensazione di forza e precisione su entrambi i sistemi Dnd®. Questa soluzione consente un ritorno della maniglia più potente e regolare, aumentando al tempo stesso durabilità, resistenza all'usura e stabilità meccanica. Il sistema e la molla interna sono stati testati e certificati dal Laboratorio AQM - Cert.2025-0667/PP1e, in base alla normativa UNI EN 1906.

Test di tenuta e usura dei componenti meccanici. Simulazione di apertura e chiusura oltre: 200.000 cicli.

Categoria d'uso Grado 3: alta frequenza d'uso da parte del pubblico o scarsa cura; alte probabilità d'uso improprio.

Durabilità Grado 7: frequenza d'uso elevata, 200.000 cicli.

Azionamento Tipo B, serrature caricate a molla.

The new mechanism for Dnd handles is made entirely of metal and replaces the old plastic rotor and the two compression springs with an innovative square-section torsion spring. It is the same spring used with our VIS system: this means that the same feeling of strength and precision can be found in both Dnd® systems. This solution allows for a more powerful and smooth handle return movement, while increasing durability, wear resistance and mechanical stability.

The system and internal spring have been tested and certified by the AQM Laboratory - Cert.2025-0667/PP1e, in accordance with UNI EN 1906.

Mechanical components wear and tear test. Opening and closing simulation to more than 200.000 cycles.

Category of use Grade 3: high frequency of use by the public or with little care; high chance of misuse.

Durability Grade 7: high frequency of use, 200.000 cycles.

Type of operation B, spring-loaded locks.

Componenti tecnici / Technical components



Less is fine

SISTEMA VIS 7 MM

VIS 7 MM SYSTEM

VIS

VIS

PORTADOOR

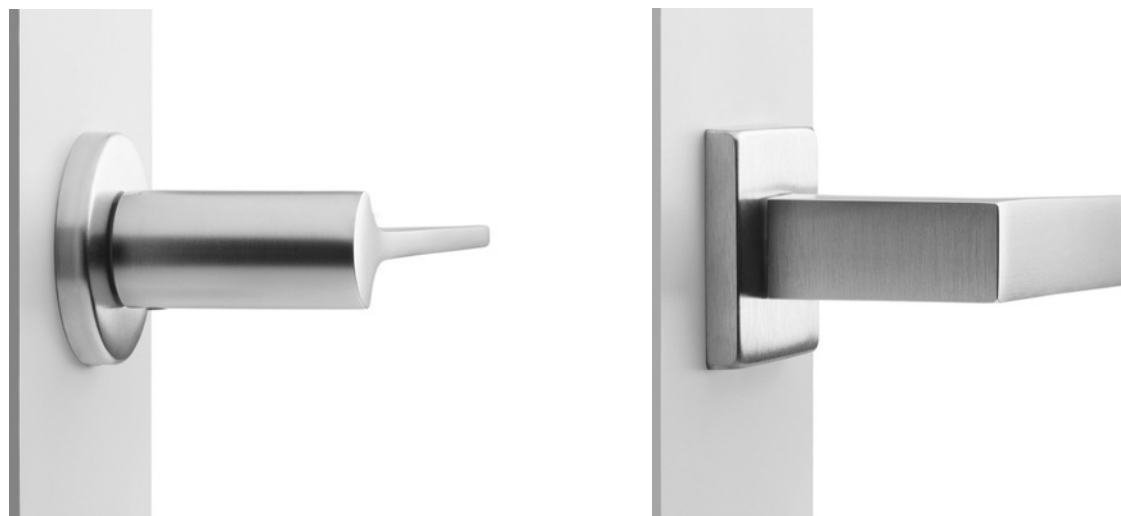

Componenti realizzati in nylon PA6 con molla uni-direzionale destra o sinistra.

Rosette con diametro 50 mm e spessore 7 mm.

Fori per fissaggio legno e interasse 38 mm per viti a connessione con o senza bussole.

Il sistema e la molla interna sono stati testati e certificati dal Laboratorio AQM - Cert.2012-1000/PPe, in base alle normative UNI EN 1906.

The parts are made with PA6 nylon, with uni-directional left or right spring.

The backplate has a diameter of 50 mm and a thickness of 7 mm.

Holes for attachment to wood, 38 mm centering, with or without connector nuts.

The inner spring and system are certified by AQM - Cert.2012-1000/Ppe in keeping with UNI EN 1906 standards.

Test di tenuta e usura dei componenti meccanici. Simulazione di apertura e chiusura oltre: 200.000 cicli.

Categoria d'uso Grado 3: alta frequenza d'uso da parte del pubblico o scarsa cura; alte probabilità d'uso improprio.

Durabilità Grado 7: frequenza d'uso elevata, 200.000 cicli. **Azionamento** Tipo B, serrature caricate a molla.

Mechanical components wear and tear test. Opening and closing simulation to more than 200.000 cycles.

Category of use Grade 3: high frequency of use by the public or with little care; high chance of misuse.

Durability Grade 7: high frequency of use, 200.000 cycles.

Type of operation B, spring-loaded locks.

Componenti tecnici / Technical components



VIS



VIS

DK VIS 9 mm



FINESTRA WINDOW



DK VIS TS 9 mm



Il DK VIS nasce dall'esigenza di ottenere un sistema esteticamente combinato con il sistema VIS per porta. Le componenti tecniche restano così più discrete e lasciano pieno spazio al design della maniglia. Un meccanismo facile e veloce da montare, senza la necessità di lavorazioni sul serramento.

DK VIS is the result of the need for aesthetic coordination with the VIS system for doors. The technical components remain more discreet to offer greater freedom in the design of the handle. The mechanism is easy and quick to assemble.

Il DK anti intrusione con pulsante di sicurezza. Studiato appositamente per evitare che, forando il serramento dall'esterno, sia possibile azionare il meccanismo. TSDK non richiede lavorazioni e può essere installato anche in sostituzione a modelli precedenti. Inoltre è configurabile con tutti i modelli a catalogo.

The DK anti-intrusion model with security latch. Specially designed to avoid the possibility of opening by drilling from the outside. TSDK does not require machining and can also be installed in place of previous models. It can also be coordinated with all the models in the catalogue.

FINITUR

E

FINISHE

S

FINITURE / FINISHES

Finiture su ottone / Brass finishes

OLV	Lucido Polished	
OS	Satinato Satin	
BSO	Bronzo sabbaiato opaco Matt sandblasted bronze	
OGH	Bronzo satinato opaco Matt satin bronze	
AB	Bronzato	
OBR	Antique bronze	
OC	Bronzo	
OCS	Cromo lucido Polished chrome	
CCS	Cromo satinato Satin chrome	
ONV	Cromo - Cromo satinato	
ONS	Chrome - Satin chrome	
ONT	Nickel lucido Polished nickel	
eco-friendly	Nickel satinato Satin nickel	NEW
ORA	Ottone naturale Natural brass	
OBN	Oro satinato Satin gold	RAL 9016
BNL	Bianco White	RAL 9010
ONO	Bianco lucido Bright white	RAL 9005
OVE	Nero Black	RAL 6009
TAN	Verde Green	
	Antracite Anthracite	

forte® Finiture PVD su ottone / PVD finishes on brass

PVD-SH forte®	Oro champagne satinato Champagne satin gold	
PVD-SB forte®	Bronzo satinato Satin bronze	
PVN forte®	Nickel lucido Bright nickel	
PVD-BG forte®	Oro antico lucido Antique bright gold	
PVD-SG forte®	Oro antico satinato Antique satin gold	
PGS forte®	Grafite satinato Satin graphite	ON DEMAND
PVD-BB forte®	Bronzo lucido Bright bronze	ON DEMAND
PVD forte®	Oro lucido Bright gold	ON DEMAND
PVD forte®	Rame satinato Satin copper	ON DEMAND
SC forte®	Inox satinato Satin steel	
PVX forte®		

Finiture su zama / Zamak finishes

ZC	Cromo lucido Polished chrome	
ZC	Cromo satinato Satin chrome	
S	Nickel satinato	
ZN	Satin nickel	RAL 9016
S	Bianco White	RAL 9005
ZB	Nero Black	
N	Antracite Anthracite	
ZN	B ro nzo B ro nze	
E	Oro satinato Satin gold	
ZA	Oro lucido Bright polished	
N	Finiture su acciaio inox / Stainless steel finishes	
ZB		
S316	Acciaio AISI 316 satinato AISI 316 satin steel	
S316/N	Nero Black	
Q316 +	AISI 316 lucido + inserto rame PVD AISI 316 polished + PVD copper insert	
R316	AISI 316 satinato + inserto rame PVD AISI 316 satin + PVD copper insert	
R	AISI 316 lucido + inserto rame nero AISI 316 polished + copper black insert	
L316 +	AISI 316 satinato + inserto rame nero AISI 316 satin + copper black insert	
N S316		
+ N		

Finiture su alluminio / Aluminium finishes

ACS	Cromo satinato Satin chrome	
ANT	Alluminio naturale Natural aluminium	NEW
eco-friendly	Silver	
ASV	Silver	
ARO	Oro satinato Satin gold	
ABR	B ro nzo B ro nze	RAL 9016
ABN	Bianco White	RAL 9005
ANE	Nero Black	RAL 5018
ABT	Turchese Turquoise	RAL 4009
AVP	Violetto pastello Pastel violet	RAL 1020
AGO	Giallo oliva Yellow olive	RAL 5014
ABC	Blu colomba Blue dove	

forte®

forte® è il termine coniato da Dnd per identificare e dare enfasi alla speciale finitura per maniglie che si ottiene grazie alla tecnologia di rivestimento PVD. Acronimo di Physical Vapour Deposition, PVD è una tecnologia di rivestimento per prodotti di alta qualità dalle eccellenti caratteristiche chimiche e tecniche, quali alta durezza, resistenza all'abrasione, ai graffi e alla corrosione. Un rivestimento che è perfettamente sostenibile, a impatto ambientale ridotto e ipoallergenico.

forte® is the term coined by Dnd to identify and emphasise the special finish for handles that is achieved thanks to PVD coating technology. An acronym for Physical Vapour Deposition, PVD is a coating technology for high quality products with excellent chemical and technical characteristics, such as high hardness, resistance to abrasion, scratching and corrosion. A coating that is perfectly sustainable, with low environmental impact and it is hypoallergenic.

AVAILABLE



PVD-SH forte®
Oro champagne satinato
Champagne satin gold



PVD-SB forte®
Bronzo satinato
Satin bronze



PVN forte®
Nickel lucido
Bright nickel



PVD-BG forte®
Oro antico lucido
Antique bright gold



PVD-SG forte®
Oro antico satinato
Antique satin gold



PGS forte®
Grafite satinato
Satin graphite

ON DEMAND



PVD-BB forte®
Bronzo lucido
Bright bronze



PVD forte®
Oro lucido
Bright gold



PVD-SCB forte®
Rame satinato
Satin copper



PVX forte®
Inox satinato
Satin steel

MASSIMA RESISTENZA GARANTITA TOTAL RESISTANCE GUARANTEED

La tecnologia PVD, il cui processo fisico avviene all'interno di camere ad alto vuoto, si basa sul deposito di film sottili sui diversi materiali: alcuni metalli – come titanio, zirconio e cromo – vengono vaporizzati e grazie all'energia cinetica posseduta sono attratti sulla superficie degli oggetti, dove poi condensano e formano il rivestimento desiderato, realizzabile in molti colori.

- Alta resistenza alla corrosione, al graffio, all'abrasione anche in zone marine
- Estrema durezza superficiale
- Atossicità, anallergicità, biocompatibilità
- Inattaccabilità da parte di solventi e prodotti di pulizia per uso domestico e industriale
- Inalterabilità alla luce e nel tempo

The PVD technology, whose physical process takes place inside a high-vacuum chamber, is based on the deposition of thin films on various materials: certain metals – like titanium, zirconium and chromium – are vaporized, and thanks to kinetic energy are drawn to the surface of objects, where they condense and form the desired coating, which can be made in many colors.

- High resistance to corrosion, scratching and abrasion, also in marine zones
- Extreme surface hardness
- Non-toxic, anallergic, biocompatible
- Impregnable to solvents and cleaning products for domestic and industrial use
- Not altered by light over time and stability over time

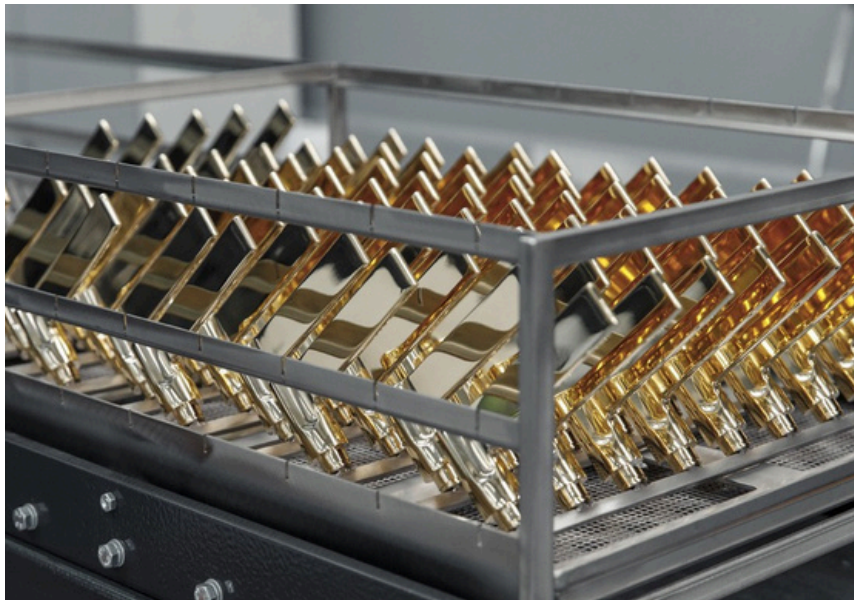

forte[®]

PVD, alta qualità nella tecnologia del rivestimento

PVD: high quality in coating technology

PVD-SH forte®

Oro champagne satinato

Champagne satin gold



PVD-SH forte®

Oro champagne satinato.

Una texture elegante e finemente satinata che stupisce per il suo colore unico, capace di illuminare e caratterizzare interni sobriamente ricercati. Finitura garantita 30 anni.

PVD-SH forte®

Champagne satin gold.

An elegant texture with a fine satin finish that sets the scene with its unique hue, which both illuminates and characterises subtly refined interiors. Finish guaranteed for 30 years.

ANIK LINE
Gabriele &
Oscar Buratti

forte®



PVD-SB forte® Bronzo satinato Satin bronze



PVD-SB forte® Bronzo satinato.

Il caldo colore del bronzo con un effetto satinato: un tono scuro e al contempo non statico, in grado di riflettere la luce e stupire in interni dagli stili più differenti. Finitura garantita 10 anni.

PVD-SB forte® Satin bronze. A warm bronze shade with a satin effect: a dark yet non-static tone, able to reflect light and set the scene, no matter the interior style. Finish guaranteed for 10 years.

ANIK
Gabriele &
Oscar Buratti

forte[®]



PVN forte® Nickel lucido Bright nickel



PVN forte® Nickel lucido.

Una cromatura a specchio caratterizzata da un tono caldo, dato dalla presenza del nickel. Una finitura versatile, fresca e luminosa, adatta agli ambienti più diversi. Finitura garantita 30 anni.

PVN forte® Bright nickel.

A mirror-effect chrome plating with a warm tone, thanks to the presence of nickel. A versatile, fresh and bright finish that is suitable for the most diverse settings. Finish guaranteed for 30 years.

ANIK BRILLIANT
Gabriele &
Oscar Buratti

forte®



PVD-BG forte® Oro antico lucido Antique bright gold



PVD-BG forte® Oro antico lucido.

Il colore dell'ottone proposto in una tonalità più calda: per un segno brillante e luminoso, dal fascino intramontabile. Finitura garantita 30 anni.

PVD-BG forte® Antiquebright gold.

The colour of brass in a warmer tone: for a bright, luminous presence of timeless charm. Finish guaranteed for 30 years.

MADELEINE
Inga Sempé

forte[®]



PVD-SG forte®

Oro antico satinato

Antique satin gold



PVD-SG forte® **Oro antico satinato.**

Solido, raffinato e senza tempo, un tono dell'ottone in grado di valorizzare al meglio sia ambienti dal sapore di un tempo, sia interni dal disegno minimale. Finitura garantita 30 anni.

PVD-SG forte® **Antique satin gold.**

Solid, refined and timeless, a tone of brass that is at its best in settings with the spirit of bygone days, but also in contexts of minimalist design. Finish guaranteed for 30 years.

GINKGO
Giulio Iacchetti

forte®



PGS forte® Grafite satinato Satin graphite



PGS forte® Grafite satinato.

Ottone con finitura grafite satinato.
Un tono tra il grigio scuro e il nero: un
colore originale per far emergere l'oggetto
maniglia in ambienti connotati da una
grande attenzione al progetto.
Finitura garantita 10 anni.

PGS forte® Satin graphite.

Brass with satin graphite finish.
A tone between dark gray and black:
an original colour to make the
handle stand out in contexts
of great design refinement.
Finish guaranteed for 10 years.

BLEND
967arch

forte[®]



FINITURE NATURALI / NATURAL FINISHES

Con le nuove finiture naturali ONT (Ottone Naturale) e ANT (Alluminio Naturale), Dnd riscrive il rapporto tra design e sostenibilità.

Il processo produttivo si semplifica, si fa più efficiente e consapevole, riducendo gli sprechi e valorizzando la materia prima nella sua essenza più autentica. Le superfici, lasciate libere di evolvere nel tempo, esprimono un'estetica viva e mutevole, capace di raccontare il valore del cambiamento.

ONT e ANT non sono solo finiture: sono un manifesto di innovazione, in cui forma e funzione si fondono con una nuova responsabilità ambientale.

With the new natural finishes ONT (Natural Brass) and ANT (Natural Aluminium), Dnd rewrites the relationship between design and sustainability.

The production process becomes simpler, more efficient and conscious, reducing waste and enhancing the raw material in its most authentic essence.

The surfaces, left free to evolve over time, express a living and changing aesthetic, capable of telling the value of change.

ONT and ANT are not just finishes: they are a manifesto of innovation, in which form and function merge with a new environmental responsibility.





RESPONSABILITÀ PRODUTTIVA / SUSTAINABLE MANUFACTURING

Ogni scelta produttiva compiuta da Dnd punta a una riduzione concreta dell'impatto ambientale, portando il design verso una necessaria sostenibilità.

Le nuove finiture naturali, unite all'uso crescente di energia rinnovabile e a un ciclo di vita interamente riciclabile, permettono di definire un nuovo standard di produzione sostenibile, senza rinunciare alla qualità e alla bellezza del design.

Every production choice made by Dnd aims at a concrete reduction of environmental impact, leading design towards a sustainability.

The new natural finishes, combined with the increasing use of renewable energy and a fully recyclable life cycle, help define a new standard in sustainable production, without compromising the quality and beauty of design.



- 60%** **EMISSIONI CO2**
CO2 EMISSIONS
- 90%** **CONSUMO ENERGETICO**
ENERGY CONSUMPTION
- 100%** **RICICLABILE**
RECYCLABLE

Rispetto ai trattamenti tradizionali come il PVD, le finiture naturali ONT e ANT riducono fino al 90% il consumo energetico e le emissioni di CO₂ si abbassano del 60% grazie a una ridotta movimentazione dei pezzi. Anche in termini di riciclabilità, il salto è netto: mentre i rivestimenti superficiali pregiati rendono difficile il riutilizzo dei materiali, le finiture naturali consentono una riciclabilità completa, pari al 100%.

Compared to traditional treatments such as PVD, ONT and ANT natural finishes reducing energy consumption by up to 90% and CO₂ emissions are reduced by 60% thanks² to reduced parts handling. Even in terms of recyclability, the leap is clear: while high-quality surface coatings make it difficult to reuse materials, natural finishes allow for complete recyclability, amounting to 100%.



Le finiture naturali Dnd
Dnd natural finishes

FINITURE CROMATE / CHROME FINISHES

Finiture galvaniche in cromo e nickel
per superfici lucide e satinato.

Chrome and nickel galvanic finishes
for polished and brushed surfaces.



Cromo lucido
Polished chrome
OC - Ottone / Brass
ZC - Zama / Zamak



Cromo satinato
Satin chrome
OCS - Ottone / Brass
ZCS - Zama / Zamak
ACS - Alluminio / Aluminium



Nickel satinato
Satin nickel
ONS - Ottone / Brass
ZNS - Zama / Zamak

FINITURE DORATE E BRONZATE / GOLDEN AND BRONZE FINISHES

Il prestigio dell'ottone resobrillante
satinato tramite spazzolature e finiture
artigianali realizzate da mani esperte.

The prestige of brass, honed or satinated by
brushing and handmade finishing by skilled
artisans.



Lucido
Polished
OLV - Ottone / Brass



Satinato
Satin
OS - Ottone / Brass



Bronzo satinato opaco
Matt satin bronze
OGH - Ottone / Brass



Bronzo sabbato opaco
Matt sandblasted bronze
BSO - Ottone / Brass



Bronzato
Antique bronze
AB - Ottone / Brass

FINITURE COLORATE / COLOURED FINISHES

Toni inediti e originali per dare spazio alla creatività.

New, original tones to give room for creativity.



Bianco lucido
Bright white
BNL - Ottone / Brass



Bianco
White
OBN - Ottone / Brass
ZBN - Zama / Zamak
ABN - Alluminio / Aluminium



Nero
Black
ONO - Ottone / Brass
ZNE - Zama / Zamak
ANE - Alluminio / Aluminium



Verde
Green
OVE - Ottone / Brass



Giallo oliva
Yellow olive
AGO - Alluminio / Aluminium



Violetto pastello
Pastel violet
AVP - Alluminio / Aluminium



Blu colomba
Alluminio / Aluminium



Turchese
Blue dove
Turquoise
ABC - Alluminio / Aluminium
ABT - Alluminio / Aluminium



Antracite
Anthracite
Ottone / Brass
TAN - Ottone / Brass
ZAN - Zama / Zamak



Silver
Silver
Alluminio / Aluminium
ASV - Alluminio / Aluminium



Oro satinato
Satin gold
Ottone / Brass
ORA - Ottone / Brass
ZRO - Zama / Zamak
ARO - Alluminio / Aluminium



Bronzo
Bronze
Ottone / Brass
OBR - Ottone / Brass
ZBR - Zama / Zamak
ABR - Alluminio / Aluminium

MANIGLIE ALTA GAMMA

HIGH-END DOOR HANDLES

BIG - Bjarke Ingels Group



Jakob Lange - BIG Partner

BIG – Bjarke Ingels Group ridefinisce l'architettura contemporanea con un approccio che fonde pragmatismo e visione utopica. Operando tra Copenhagen, New York e altre metropoli globali, lo studio guidato da Bjarke Ingels ha conquistato la scena internazionale attraverso un "utopismo pragmatico" che trasforma le sfide della vita contemporanea in opportunità creative.

I progetti di BIG – Bjarke Ingels Group non solo risolvono problemi funzionali ma generano nuove possibilità sociali ed ambientali. Le diverse professionalità che animano lo studio, architetti, designer, urbanisti, paesaggisti, ricercatori e inventori, posizionano lo studio all'avanguardia del design urbano sostenibile e dell'innovazione urbana, con una profonda influenza sul linguaggio architettonico del XXI secolo.

BIG – Bjarke Ingels Group redefines contemporary architecture with an approach that blends pragmatism and utopian vision. Operating between Copenhagen, New York, and other global metropolises, the studio led by Bjarke Ingels has gained international recognition through a "pragmatic utopianism" that turns the challenges of contemporary life into creative opportunities. BIG – Bjarke Ingels Group's projects not only solve functional problems but also generate new social and environmental possibilities. The diverse professionals within the studio— architects, designers, urban planners, landscape architects, researchers, and inventors— place the firm at the forefront of sustainable design and urban innovation, with a profound influence on the architectural language of the 21st century.



Palm
Disegni della maniglia di /
Handle sketches by
BIG - Bjarke Ingels Group

PALM NEW



Pensata per adattarsi in modo naturale al palmo della mano, Palm invita al tocco e all'interazione attraverso un linguaggio di forme fluide e organiche. Le linee morbide e accoglienti della leva sono riprese nella rosetta, trasformando un gesto quotidiano in un'esperienza sensoriale dove ergonomia e design trovano un equilibrio per fetto.

Designed to fit naturally in the palm of the hand, Palm invites touch and interaction through a language of fluid and organic shapes. The soft, welcoming lines of the lever are echoed in the rosette, transforming an everyday gesture into a sensory experience where ergonomics and design find the perfect balance.

PALM NEW



archiproducts
AWARDS
WINNER
2025

archiproducts
AWARDS
WINNER
SUSTAINABILITY
2025

PALM

design:
BIG - Bjarke Ingels Group

made in italy

Ottone
Brass

® PA13



ONT | eco-friendly
Ottone naturale
Natural brass



PVD-SG | forte®
Oro antico satinato
Antique satin gold



PGS | forte®
Grafite satinato
Satin graphite



BSO
Bronzo sabbiato opaco
Matt sandblasted bronze



OCS
Cromo satinato
Satin chrome

PA13P
con bocchetta patent
with patent escutcheon



PA13Y
con bocchetta yale
with yale escutcheon



PA13T
con nottolino
with turn & release



PA35
pomolo Ø60 mm
Ø60 mm knob





PENCIL NEW

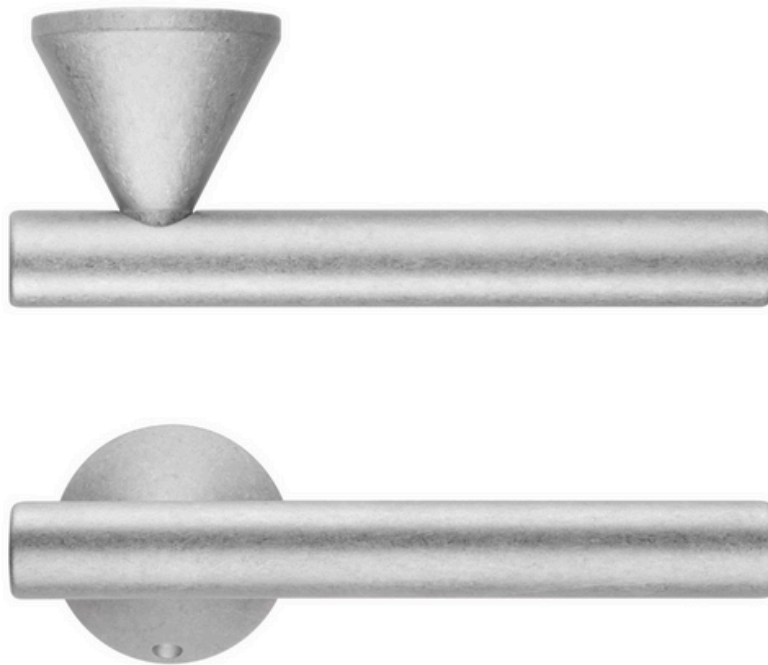

Pencil è una maniglia che distilla la forma tradizionale nella sua essenza più pura. Con un gambo affilato come la punta di una matita, crea una transizione netta e distintiva verso la leva. Una dualità che si ripresenta anche nel movimento del cilindro impugnatura distinto rispetto alla staticità della rosetta.

Pencil is a handle that distills the traditional form into its purest essence. The shank, reminiscent of the tip of a sharpened pencil creates a distinctive transition to the lever. A duality that is also present in the movement of the handle cylinder that is distinct from the static rosette.

PENCIL NEW



PENCIL

design:
BIG - Bjarke Ingels Group

Alluminio
Aluminium

made in italy

® PE01



ANT | eco-friendly
Alluminio naturale
Natural aluminium



ARO
Oro satinato
Satin gold



ABR
Bronzo
Bronze



ASV
Silver
Silver



ABN
Bianco
White



ANE
Nero
Blac
k

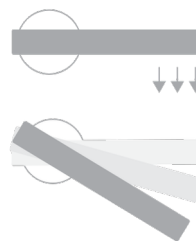

L'impugnatura cilindrica ruota indipendentemente dalla rosetta conica, che resta fissa. Un dettaglio meccanico che valorizza l'essenzialità del design.

The cylindrical handle rotates independently of the conical rose, which remains fixed. A mechanical detail that enhances the essential nature of the design.

PE01P
con bocchetta patent
with patent escutcheon



PE01Y
con bocchetta yale
with yale escutcheon



PE01T
con nottolino
with turn & release



PE39
pomolo 80x50 mm
80x50 mm knob



PE27
maniglia e pull
handle



Park



Fondato a Milano nel 2000 da Filippo Pagliani e Michele Rossi, lo studio si occupa di architettura, urban design, paesaggio, interior e product design, promuovendo un approccio trasversale. Ogni progetto sviluppato da Park trova forma nel suo specifico contesto, dagli spazi residenziali e commerciali alla riqualificazione di edifici moderni d'autore o di interi quartieri. Operando all'intersezione tra tradizione e innovazione, lo studio si distingue nel reinterpretare e rigenerare le città, trasformandole in nuovi modelli di vivibilità e sostenibilità. Il collettivo guarda avanti, anticipando l'impatto a lungo termine dei propri progetti con l'obiettivo di stabilire una nuova armonia tra l'uomo e la natura. Park ha vinto numerosi premi, tra cui il Premio Architetto Italiano 2024.

Founded in Milan in 2000 by Filippo Pagliani and Michele Rossi, the studio operates across architectural, urban design, landscape, interior, and product design, championing a cross-cutting approach. Every project developed by Park takes shape within its specific context, from residential and commercial spaces to the renovation of iconic modern buildings and entire neighborhoods. Operating at the intersection of tradition and innovation, the studio excels in reinterpreting and regenerating cities, transforming them into new models of liveability and sustainability. The collective looks ahead, anticipating the full impact of its architecture with the aim of establishing a new bond between man and nature. Park has won numerous awards, including the 2024 Italian Architect Award.

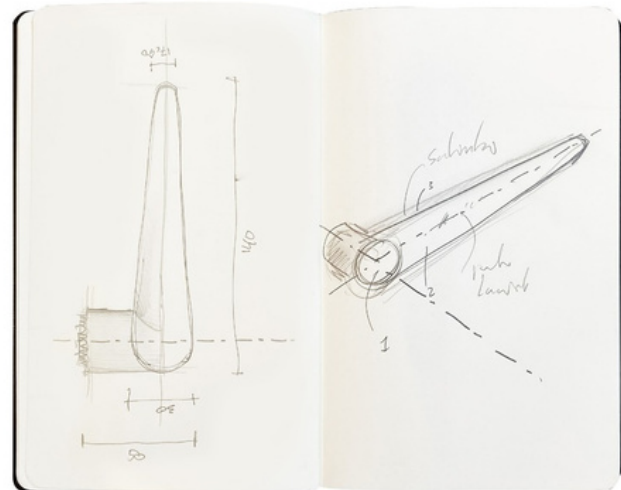

Leva
Disegni della maniglia di /
Handle sketches by
Park

LEVA



Espressione pura del concetto di leva, rimanda al mondo della meccanica e ai suoi strumenti. È caratterizzata, nella parte frontale, da un taglio netto sulla materia che si relaziona in armonia con la parte interna, arrotondata e accogliente.

A pure expression of the concept of lever, it evokes the world of mechanics and its tools. It is characterised on the front by a clean cut on the material that relates in harmony with the rounded and welcoming inner part.

LEVA

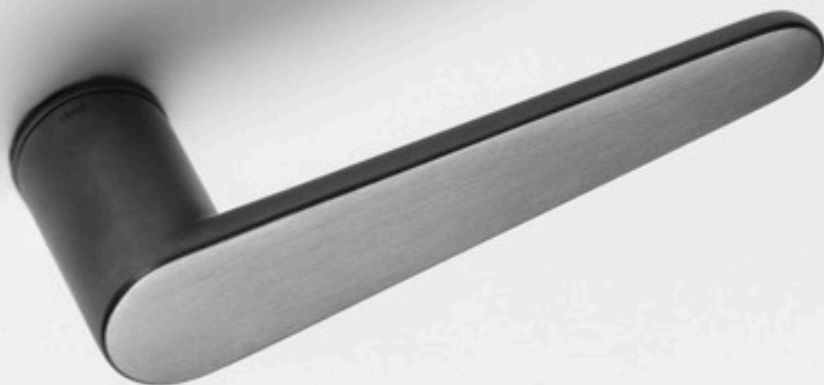

LEVA

design:
Park

Ottone
Brass

made in italy

U LV80



PVD-SG | forte®
Oro antico satinato
Antique satin gold



PVD-SH | forte®
Oro champagne satinato
Champagne satin gold



PVD-SB | forte®
Bronzo satinato
Satin bronze



PGS | forte®
Grafite satinato
Satin graphite



BSO
Bronzo sabbato opaco
Matt sandblasted bronze



OCS
Cromo satinato
Satin chrome



ONO
Nero
Black

LEVA MIRROR

U LM80



PVD-SBM | forte®
Oro antico satinato - Lucido
Antique satin gold - Bright



PGM | forte®
Grafite satinato - Lucido
Satin graphite - Bright



CCS
Cromo - Cromo satinato
Chrome - Satin chrome

U LEVA
LV22U
martellina DK Unico
Unico DK window handle

U LEVA MIRROR
LM22U
martellina DK Unico
Unico DK window handle



LEVA



LEVA

design:
Park

Ottone
Brass

made in italy

FINE LV40



PVD-SG | forte®
Oro antico satinato
Antique satin gold



PVD-SH | forte®
Oro champagne satinato
Champagne satin gold



PVD-SB | forte®
Bronzo satinato
Satin bronze



PGS | forte®
Grafite satinato
Satin graphite



BSO
Bronzo sabbato opaco
Matt sandblasted bronze



OCS
Cromo satinato
Satin chrome



ONO
Nero
Black

LEVA MIRROR

FINE LM40



PVD-SBM | forte®
Oro antico satinato - Lucido
Antique satin gold - Bright



PGM | forte®
Grafite satinato - Lucido
Satin graphite - Bright



CCS
Cromo - Cromo satinato
Chrome - Satin chrome

VIS LEVA
LV22V
martellina DK
DK window handle

VIS LEVA MIRROR
LM22V
martellina DK Unico
Unico DK window handle



Gabriele & Oscar Buratti



Gabriele Buratti, architetto e professore di Architettura degli Interni alla Facoltà del Design del Politecnico di Milano (2003-2010), e Oscar Buratti, architetto, formano lo studio di architettura e design Buratti Architetti. Diverse sono le scale del progetto su cui lo studio dei due architetti lavora in maniera trasversale, passando dall'architettura di edifici e aree urbane a quella degli interni di spazi domestici e commerciali, dal design di mobili e oggetti all'allestimento di mostre e showroom, in un percorso professionale intenso e variegato.

Numerose sono le collaborazioni con importanti aziende del settore del mobile tra cui Acerbis, Alias, B&B Italia, Caleido, Flexform, Fontana Arte, Gallotti&Radice, Gervasoni, Lema, Living Divani, Paola Lenti, Moroso, Poltrona Frau, Porada, Porro, Roca, Tecno, Vondom.

Gabriele Buratti, architect and professor of Interior Design at the Faculty of Design of Politecnico di Milano (2003-2010), and Oscar Buratti, architect, form the architecture and design studio Buratti Architetti.

The two architects studio works on a variety of project scales, ranging from the architecture of buildings and urban areas to the interior design of domestic and commercial spaces, from furniture and object design to exhibition and showroom design, in an intense and varied professional career.

They collaborates with many important brands in the furniture design sector, including Acerbis, Alias, B&B Italia, Caleido, Flexform, Fontana Arte, Gallotti&Radice, Gervasoni, Lema, Living Divani, Paola Lenti, Moroso, Poltrona Frau, Porada, Porro, Roca, Tecno, Vondom.

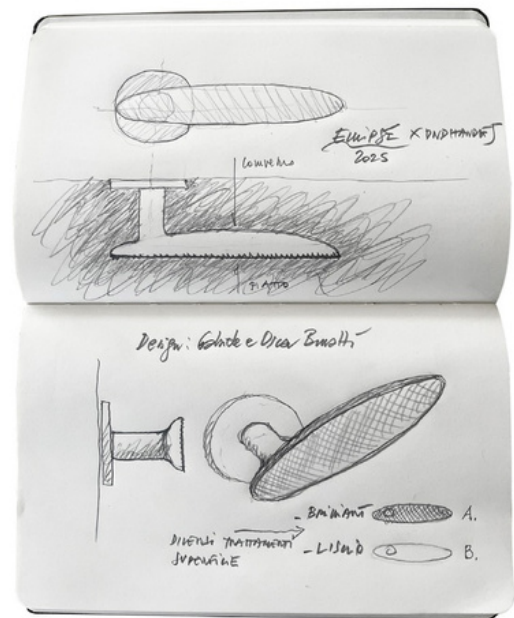

Ellipse
Disegni della maniglia di /
Handle sketches by
Gabriele & Oscar Buratti

ELLIPSE NEW



Il design si distingue per la sua capacità di unire semplicità formale e attenzione ai dettagli, reinterpretando la forma organica e fluida dell'ellisse con un tocco di raffinata eleganza geometrica.

The design stands out for its ability to combine formal simplicity and attention to detail, reinterpreting the organic and fluid shape of the ellipse with a touch of refined geometric elegance.

ELLIPSE NEW



ELLIPSE

design:
Gabriele & Oscar Buratti

Ottone
Brass

made in italy

IP40



PVD-BG | forte®
Oro antico lucido
Antique bright gold



PVD-SG | forte®
Oro antico satinato
Antique satin gold



PVD-SH | forte®
Oro champagne satinato
Champagne satin gold



PVD-SB | forte®
Bronzo satinato
Satin bronze



PVN | forte®
Nickel lucido
Bright nickel



PGS | forte®
Grafite satinato
Satin graphite



BSO
Bronzo sabbiato opaco
Matt sandblasted bronze



OCS
Cromo satinato
Satin chrome

U



ONO
Nero
Black

IP22V
martellina DK
DK window handle



IP22U
martellina DK Unico
Unico DK window handle



IP21M
mar tellina
window handle



ELLIPSE BRILLIANT



ELLIPSE BRILLIANT

design:
Gabriele & Oscar Buratti

Ottone
Brass

made in italy

IB40



PVD-BG | forte®
Oro antico lucido
Antique bright gold



PVD-SG | forte®
Oro antico satinato
Antique satin gold



PVD-SH | forte®
Oro champagne satinato
Champagne satin gold



PVD-SB | forte®
Bronzo satinato
Satin bronze



PVN | forte®
Nickel lucido
Bright nickel



BSO
Bronzo sabbato opaco
Matt sandblasted bronze



OCS
Cromo satinato
Satin chrome



ONO
Nero
Black

IB22V
martellina DK
DK window handle



IB22U
martellina DK Unico
Unico DK window handle



IB21M
mar tellina
window handle



ANIK

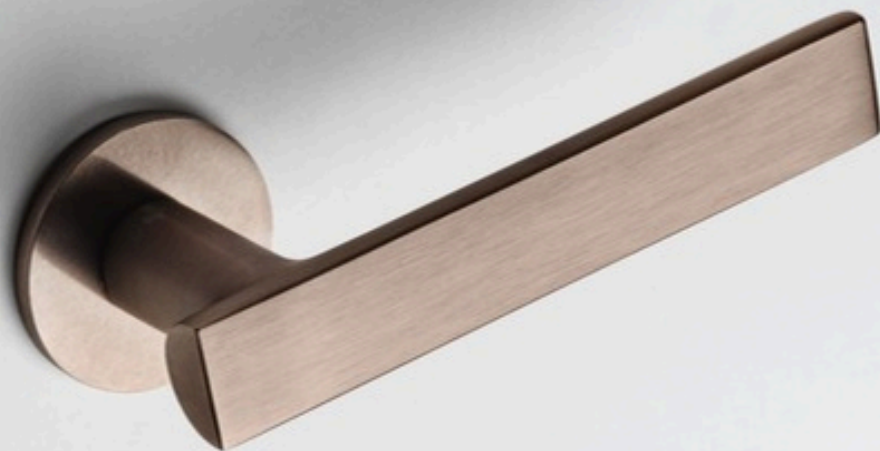

ANIK

design:
Gabriele & Oscar Buratti

Ottone
Brass

made in italy

FINE AK40



PVD-BG | forte®
Oro antico lucido
Antique bright gold



PVD-SG | forte®
Oro antico satinato
Antique satin gold



PVD-SH | forte®
Oro champagne satinato
Champagne satin gold



PVD-SB | forte®
Bronzo satinato
Satin bronze



PVN | forte®
Nickel lucido
Bright nickel



PGS | forte®
Grafite satinato
Satin graphite



BSO
Bronzo sabbiato opaco
Matt sandblasted bronze



OCS
Cromo satinato
Satin chrome



ONO
Nero
Black

VIS AK22V
martellina DK
DK window handle



U AK22U
martellina DK Unico
Unico DK window handle



AK21M
mar tellina
window handle



ANIK 02



ANIK 02

design:
Gabriele & Oscar Buratti

Ottone
Brass

made in italy

FINE AK41



PVD-BG | forte®
Oro antico lucido
Antique bright gold



PVD-SG | forte®
Oro antico satinato
Antique satin gold



PVD-SH | forte®
Oro champagne satinato
Champagne satin gold



PVD-SB | forte®
Bronzo satinato
Satin bronze



PVN | forte®
Nickel lucido
Bright nickel



PGS | forte®
Grafite satinato
Satin graphite



BSO
Bronzo sabbato opaco
Matt sandblasted bronze



OCS
Cromo satinato
Satin chrome



ONO
Nero
Black

R AK25
martellina DK
DK window handle



AK24M
mar tellina
window handle



ANIK BRILLIANT



ANIK BRILLIANT

design:
Gabriele & Oscar Buratti

Ottone
Brass

made in italy

AB40



PVD-BG | forte®
Oro antico lucido
Antique bright gold



PVD-SG | forte®
Oro antico satinato
Antique satin gold



PVD-SH | forte®
Oro champagne satinato
Champagne satin gold



PVD-SB | forte®
Bronzo satinato
Satin bronze



PVN | forte®
Nickel lucido
Bright nickel



BSO
Bronzo sabbato opaco
Matt sandblasted bronze



OCS
Cromo satinato
Satin chrome



ONO
Nero
Black

AB22V
martellina DK
DK window handle



AB22U
martellina DK Unico
Unico DK window handle

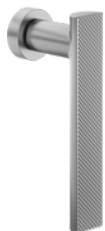

AB21M
mar tellina
window handle



ANIK BRILLIANT 02

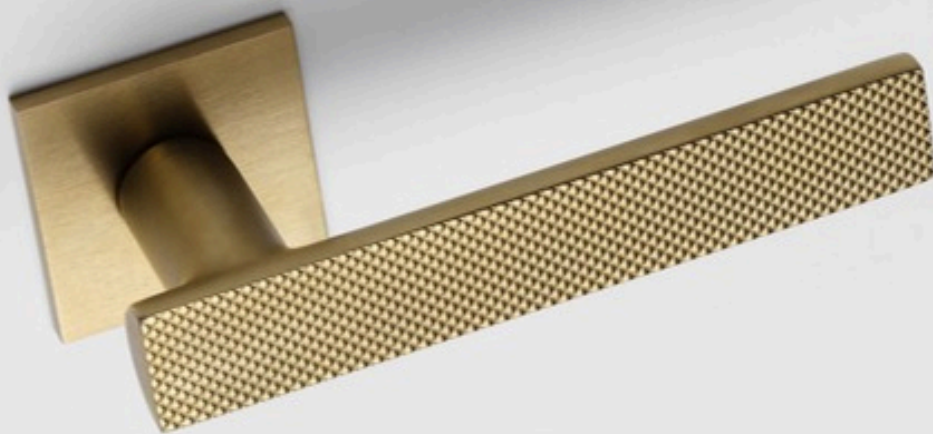

ANIK BRILLIANT 02

design:
Gabriele & Oscar Buratti

Ottone
Brass

made in italy

FINE AB41



PVD-BG | forte®
Oro antico lucido
Antique bright gold



PVD-SG | forte®
Oro antico satinato
Antique satin gold



PVD-SH | forte®
Oro champagne satinato
Champagne satin gold



PVD-SB | forte®
Bronzo satinato
Satin bronze



PVN | forte®
Nickel lucido
Bright nickel



BSO
Bronzo sabbato opaco
Matt sandblasted bronze



OCS
Cromo satinato
Satin chrome



ONO
Nero
Black

R AB25
martellina DK
DK window handle



AB24M
mar tellina
window handle



ANIK LINE



ANIK LINE

design:
Gabriele & Oscar Buratti

Ottone
Brass

made in italy

AE40



PVD-BG | forte®
Oro antico lucido
Antique bright gold



PVD-SG | forte®
Oro antico satinato
Antique satin gold



PVD-SH | forte®
Oro champagne satinato
Champagne satin gold



PVD-SB | forte®
Bronzo satinato
Satin bronze



PVN | forte®
Nickel lucido
Bright nickel



BSO
Bronzo sabbato opaco
Matt sandblasted bronze



OCS
Cromo satinato
Satin chrome



ONO
Nero
Black

AE22V
martellina DK
DK window handle



AE22U
martellina DK Unico
Unico DK window handle



AE21M
mar tellina
window handle



ANIK LINE 02

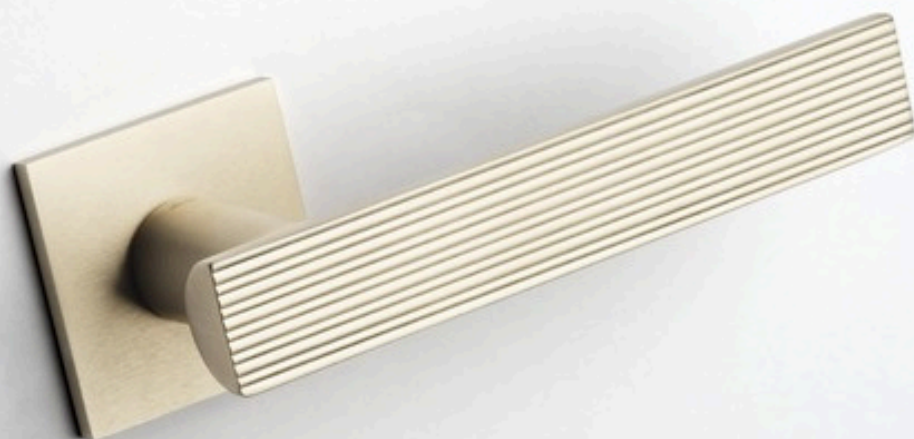

ANIK LINE 02

design:
Gabriele & Oscar Buratti

Ottone
Brass

made in italy

FINE AE41



PVD-BG | forte®
Oro antico lucido
Antique bright gold



PVD-SG | forte®
Oro antico satinato
Antique satin gold



PVD-SH | forte®
Oro champagne satinato
Champagne satin gold



PVD-SB | forte®
Bronzo satinato
Satin bronze



PVN | forte®
Nickel lucido
Bright nickel



BSO
Bronzo sabbato opaco
Matt sandblasted bronze

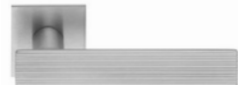

OCS
Cromo satinato
Satin chrome



ONO
Nero
Black

R AE25
martellina DK
DK window handle



AE24M
mar tellina
window handle



Elena Salmistraro



Product designer ed artista, vive e lavora a Milano. Si laurea in industrial design al Politecnico di Milano e nel 2009 fonda il proprio studio che si occupa di architettura e design, collaborando come product designer e illustratrice con molte aziende dell'industria creativa. È interessata allo sviluppo di un lavoro che si collochi a cavallo tra illustrazione, design e arti visive, mediante il quale intende definire un personale codice comunicativo. Tra le priorità delle sue creazioni, spiccano l'attenzione al dettaglio e la ricerca armonica delle forme, inseguite nell'antropomorfismo e nel primitivismo. Un eccesso di simboli grafici offre all'oggetto un'immagine stereoscopica trasportandolo in un territorio sospeso tra fantasia e realtà.

Product designer and artist, she lives and works in Milan. She graduated in industrial design at the Politecnico di Milano and in 2009 founded her studio that works in architecture and design, collaborating as a product designer and illustrator with many companies in the creative industry. She is interested in developing work that combines illustration, design and visual arts, through which she intends to define a personal code of communication. Among the priorities of her creations, emerge attention to detail and the harmonious search for forms pursued in anthropomorphism and primitivism. An excess of graphic symbols gives the object a stereoscopic image, transporting it into a territory suspended between fantasy and reality.

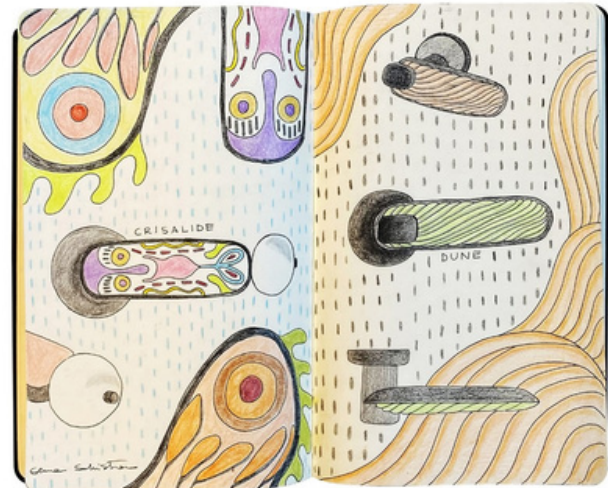

Crisalide e Dune
Disegni delle maniglie di /
Handles sketches by
Elena Salmistraro

CRISALIDE



Colori vivaci e segni primitivi per una maniglia che rimanda al variopinto mondo animale. Un metamorfismo e una leggerezza intrinseca che sono proprie del mondo delle farfalle e diventano tratto distintivo di una maniglia funzionale ma sempre pronta a librarsi in volo.

Vibrant colours and primitive signs come together in a handle that reflects the world of animals. It captures the essence of metamorphosis and inherent lightness, reminiscent of butterflies, becoming the distinctive feature of a functional handle that is always ready to take flight.

CRISALIDE

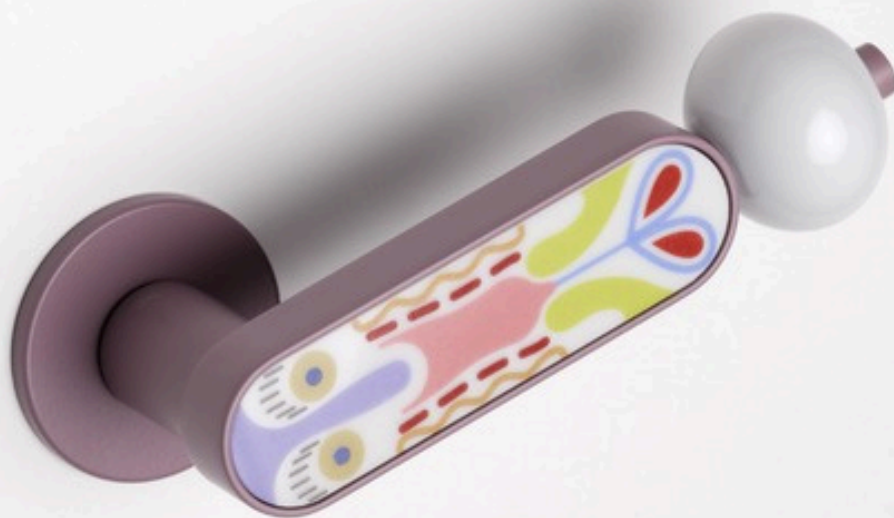

archiproducts
AWARDS
WINNER
2023

CRISALIDE

design:
Elena Salmistraro

Alluminio + porcellana
Aluminium + porcelain

made in italy

CS40



ARO + PSD
Orosatinato + porcellana lucida decorata
Satin gold + decorated glossy porcelain



AVP + PSD
Violettopastello + porcellana lucida decorata
Pastel violet + decorated glossy porcelain



ARO + PSW
Orosatinato + porcellana lucida bianca
Satin gold + white glossy porcelain



ABN + PSD
Bianco + porcellana lucida decorata
White + decorated glossy porcelain



ABC + PSD
Blucolomba + porcellana lucida decorata
Blue dove + decorated glossy porcelain



ANE + PSW
Nero + porcellana lucida bianca
Black + white glossy porcelain



ANE + PSD
Nero + porcellana lucida decorata
Black + decorated glossy porcelain

CS22V
martellina DK
DK window handle



CS22U
martellina DK Unico
Unico DK window handle



CS70
pomolino per mobile
furniture knob



CS71
pomolino per mobile
furniture knob



CS72
appendino
hanger



CRISALIDE MINI

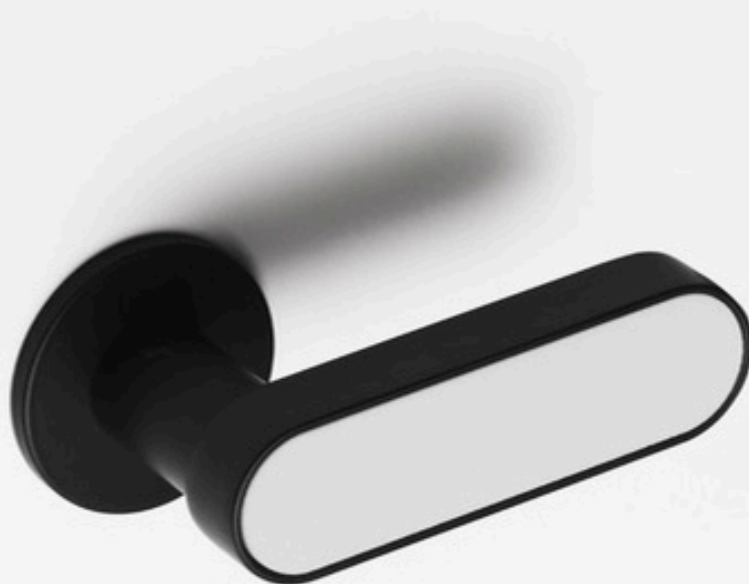

CRISALIDE MINI

design:
Elena Salmistraro

Alluminio + porcellana
Aluminium + porcelain

made in italy

CM40



ARO + PSD

Orosatinato +porcellana lucida decorata

Satin gold + decorated glossy porcelain



AVP + PSD

Violettopastello + porcellana lucida decorata

Pastel violet + decorated glossy porcelain



ARO + PSW

Orosatinato +porcellana lucida bianca

Satin gold + white glossy porcelain

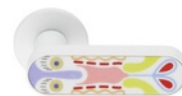

ABN + PSD

Bianco + porcellana lucida decorata

White + decorated glossy porcelain



ABC + PSD

Blucolomba +porcellana lucida decorata

Blue dove + decorated glossy porcelain



ANE + PSW

Nero + porcellana lucida bianca

Black + white glossy porcelain



ANE + PSD

Nero + porcellana lucida decorata

Black + decorated glossy porcelain

CM22V
martellina DK
DK window handle



CM22U
martellina DK Unico
Unico DK window handle



DUNE

white



DUNE

design:
Elena Salmistraro

made in italy

Ottone + porcellana lucida
bianco sabbia
Brass + sand-white glossy
porcelain

DN40



PVD-BG | forte® + PSB
Oro antico lucido
Antique bright gold



PVD-SG | forte® + PSB
Oro antico satinato
Antique satin gold



BSO + PSB
Bronzo sabbato opaco
Matt sandblasted bronze



OC + PSB
Cromo lucido
Polished chrome



OBN + PSB
Bianco
White



ONO + PSB
Nero
Black

DN22V
martellina DK
DK window handle



DN22U
martellina DK Unico
Unico DK window handle



DN70
pomolino per mobile
furniture knob



DUNE

green



DUNE

design:
Elena Salmistraro

made in italy

Ottone + porcellana lucida
verde menta
Brass + mint-green glossy
porcelain

DN40



PVD-BG | forte® + PSV
Oro antico lucido
Antique bright gold



PVD-SG | forte® + PSV
Oro antico satinato
Antique satin gold



BSO + PSV
Bronzo sabbato opaco
Matt sandblasted bronze



OC + PSV
Cromo lucido
Polished chrome



OBN + PSV
Bianco
White



ONO + PSV
Nero
Black

DN22V
martellina DK
DK window handle



DN22U
martellina DK Unico
Unico DK window handle



DN70
pomolino per mobile
furniture knob



DUNE

pink



DUNE

design:
Elena Salmistraro

made in italy

Ottone + porcellana lucida
rosa nuvola

Brass + cloud-pink glossy
porcelain

DN40



PVD-BG | forte® + PSR
Oro antico lucido
Antique bright gold



PVD-SG | forte® + PSR
Oro antico satinato
Antique satin gold



BSO + PSR
Bronzo sabbato opaco
Matt sandblasted bronze



OC + PSR
Cromo lucido
Polished chrome



OBN + PSR
Bianco
White



ONO + PSR
Nero
Black

DN22V
martellina DK
DK window handle



DN22U
martellina DK Unico
Unico DK window handle



DN70
pomolino per mobile
furniture knob



Holscher Design



Studio di progettazione multidisciplinare con base a Copenhagen, in Danimarca, è attivo dal 1990 e si colloca tra le più riconosciute e premiate agenzie di progettazione della Scandinavia. Holscher Design è diretto da un team di cinque soci, è fortemente radicato nella tradizione dei Paesi del Nord e sviluppa progetti a livello internazionale in diversi ambiti, tra cui illuminazione, sanitari, componenti per l'edilizia, design urbano. Tra le collaborazioni, Geberit, Flos, JCDecaux, Philips, Lamy.

A multidisciplinary design firm based in Copenhagen, Denmark, Holscher Design has been active since 1990 and is amongst the most well-established and award-winning design agencies in Scandinavia. The studio is headed up by a team of five partners, with deep roots in the tradition of the Nordic countries, and develops international projects spanning various fields, including lighting, sanitaryware, construction components and urban design. Its many collaborations include Geberit, Flos, JCDecaux, Philips and Lamy.

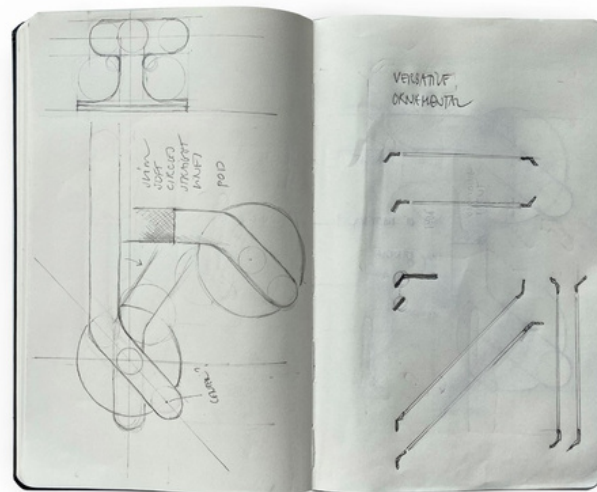

Pod
Disegni della maniglia di /
Handle sketches by
Holscher Design

POD



Una serie realizzata con una lavorazione dedicata e originale: un tondino di materiale tornito alle estremità e opportunamente inclinato di 45 gradi, per generare un gesto dinamico ed equilibrato sull'orizzontalità della leva.

A series created with a dedicated and original manufacturing process: a rod of material is turned at each end and carefully bent at a 45 degrees angle, making for a dynamic and balanced gesture on the horizontal bar of the lever.

POD



POD

design:
Holscher Design

Ottone
Brass

made in italy

FINE PD40



PVD-BG | forte®
Oro antico lucido
Antique bright gold



PVD-SG | forte®
Oro antico satinato
Antique satin gold



PGS | forte®
Grafite satinato
Satin graphite



OC
Cromo lucido
Polished chrome



OCS
Cromo satinato
Satin chrome



ONO
Nero
Black

RDN77+A
nottolino
turn & release



PD27
maniglia
e pull
handle

Alfonso Femia

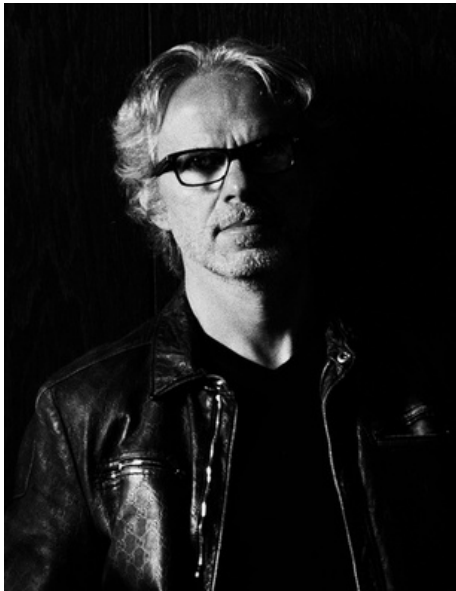

Originario di Taurianova (RC), vive tra Genova, Milano e Parigi. Laureato presso la Facoltà di Architettura dell'Università di Genova nel 1992, è iscritto all'Ordine degli Architetti di Genova, dell'Île-de-France e della Svizzera.

Ha insegnato Progettazione Architettonica alla Kent State University di Firenze, alla Facoltà di Architettura di Ferrara e a quella di Genova. Fondatore di 5+1 nel 1995, crea 5+1AA nel 2005 e 5+1AA Parigi nel 2007. Tra i suoi progetti, la nuova sede BNP Paribas a Roma, i Docks di Marsiglia, le OGR di Torino.

Born in Taurianova (RC), he lives between Genoa, Milan and Paris. With a degree from the School of Architecture of the University of Genoa in 1992, he is a member of the Architects Associations of Genoa, Île-de-France and Switzerland.

He has taught Architectural Design at Kent State University in Florence, and the Schools of Architecture of Ferrara and Genoa. He was a founder of 5+1 in 1995, and created 5+1AA in 2005 and 5+1AA Paris in 2007. His projects include the new BNP Paribas headquarters in Rome, the Docks of Marseille, the OGR in Turin.

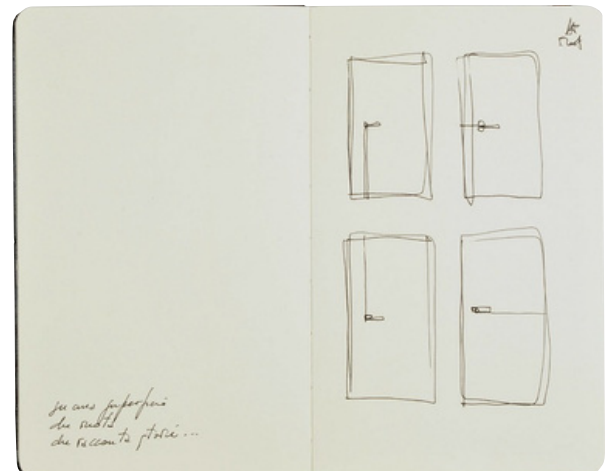

(IN)finito
Disegni della maniglia di /
Handle sketches by
Alfonso Femia

(IN) FINITO



Come un filo bidimensionale che arriva dai bordi della porta, disegna la maniglia e poi continua il suo viaggio, ora verso l'altro lato, ora verso l'alto, ora nell'altra direzione.

Like a two-dimensional line that arrives from the edges of the door and draws the handle before continuing on its way, towards the other side, upward, in the opposite direction.

(IN) FINITO



Selezionato ADI DESIGN 2019
Selected for ADI DESIGN 2019

(IN)FINITO

IF10/L



OLV
Lucido
Polished



AB
Bronzato
Antique bronze

design:
Alfonso Femia

made in italy



OC
Cromo lucido
Polished chrome

Ottone
Brass



OCS
Cromo satinato
Satin chrome



ONO
Nero
Black



Visualizza i disegni tecnici
View technical drawings

IF25
martellina DK
DK window handle



IF31
maniglia
e pull
handle



(IN)FINITO



(IN)FINITO

IF10

design:
Alfonso Femia

made in italy

Ottone
Brass



PVD-SB | forte®
Bronzo satinato
Satin bronze



PGS | forte®
Grafite satinato
Satin graphite



OLV
Lucido
Polished



AB
Bronzato
Antique bronze



OC
Cromo lucido
Polished chrome



OCS
Cromo satinato
Satin chrome



ONO
Nero
Black



Visualizza i disegni tecnici
View technical drawings

IF25
martellina DK
DK window handle



IF29
maniglia
e pull
handle



(IN)FINITO

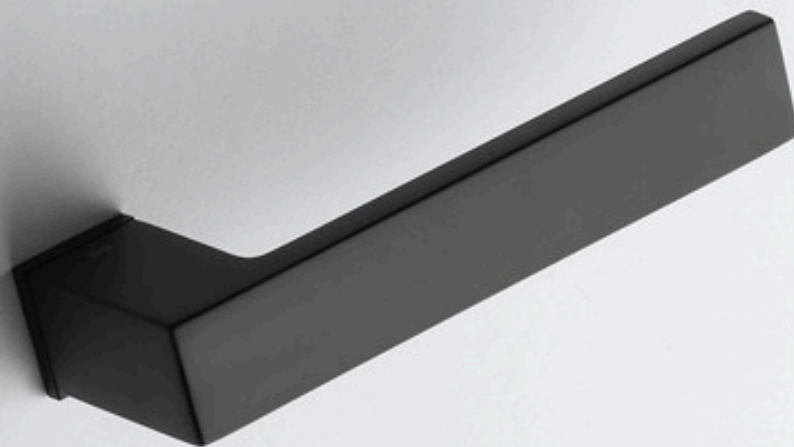

(IN)FINITO

design:
Alfonso Femia

Ottone
Brass

made in italy

IF01



PVD-SB | forte®
Bronzo satinato
Satin bronze



PGS | forte®
Grafite satinato
Satin graphite



OLV
Lucido
Polished



AB
Bronzato
Antique bronze



OC
Cromo lucido
Polished chrome



OCS
Cromo satinato
Satin chrome



ONO
Nero
Black

R IF25
martellina DK
DK window handle



ED26M
mar tellina
window handle



IF27
maniglia
e pull
handle



RDN66+A
nottolino
turn & release



(IN)FINITO



(IN)FINITO

design:
Alfonso Femia

Ottone
Brass

made in italy

IF11



PVD-SB | forte®
Bronzo satinato
Satin bronze



PGS | forte®
Grafite satinato
Satin graphite



OLV
Lucido
Polished



AB
Bronzato
Antique bronze



OC
Cromo lucido
Polished chrome



OCS
Cromo satinato
Satin chrome



ONO
Nero
Black

R IF25
martellina DK
DK window handle



ED26M
mar tellina
window handle



(IN)FINITO

design:
Alfonso Femia
made in italy

Ottone
Brass

IF40



PVD-SB | forte®
Bronzo satinato
Satin bronze



PGS | forte®
Grafite satinato
Satin graphite



OLV
Lucido
Polished



AB
Bronzato
Antique bronze



OC
Cromo lucido
Polished chrome



OCS
Cromo satinato
Satin chrome



ONO
Nero
Black

(IN)FINITO

design:
Alfonso Femia

Ottone
Brass

made in italy

IF41



PVD-SB | forte®
Bronzo satinato
Satin bronze



PGS | forte®
Grafite satinato
Satin graphite



OLV
Lucido
Polished



AB
Bronzato
Antique bronze



OC
Cromo lucido
Polished chrome



OCS
Cromo satinato
Satin chrome



ONO
Nero
Black

IF25
martellina DK
DK window handle



ED26M
mar tellina
window handle



IF27
maniglia
e pull
handle



Marco Pisati



Laureato in “Design Aerospaziale”, in collaborazione con NASA ed ALENIA SPAZIO, ha lavorato in I.A.C.S.A per l’Agenzia Spaziale Italiana. Nel 2003 apre il suo studio a Firenze e collabora con numerose aziende italiane: DND, Antonio Lupi, Martinelli Luce, De Castelli, Emilio Pucci, Cordivari, Treemme Rubinetterie, Vaselli, Cristina Rubinetterie, Inkiostro Bianco, Mogg. Vince numerosi premi internazionali quali: ADI Design Index, German Design Award Gold, Red Dot Award, Grand Prix du Design Gold, Archiproducts Awards, Iconic Awards, ADI Ceramics and Bathroom Design Award.

Graduate in Aerospace Design, in collaboration with NASA and ALENIA SPAZIO, he worked at I.A.C.S.A. for the Italian Space Agency. In 2003, he opened his own studio in Florence and has since collaborated with numerous Italian companies, including DND, Antonio Lupi, Martinelli Luce, De Castelli, Emilio Pucci, Cordivari, Treemme Rubinetterie, Vaselli, Cristina Rubinetterie, Inkiostro Bianco, and Mogg. He has received numerous international awards, including the ADI Design Index, German Design Award Gold, Red Dot Award, Grand Prix du Design Gold, Archiproducts Awards, Iconic Awards, and the ADI Ceramics and Bathroom Design Award.

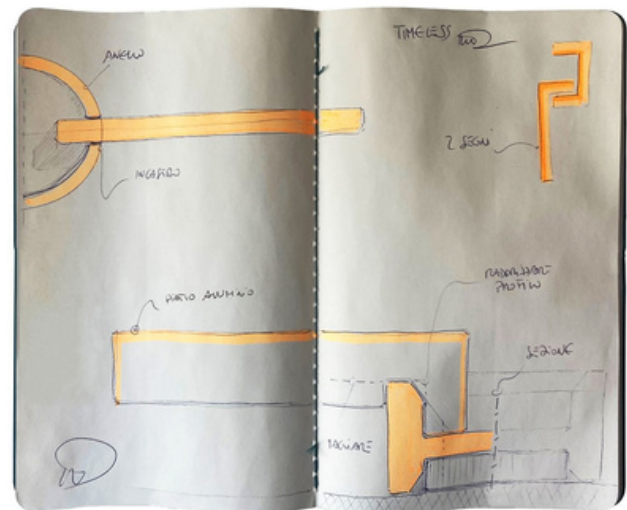

Timeless
Disegni della maniglia di /
Handle sketches by
Marco Pisati

TIMELESS

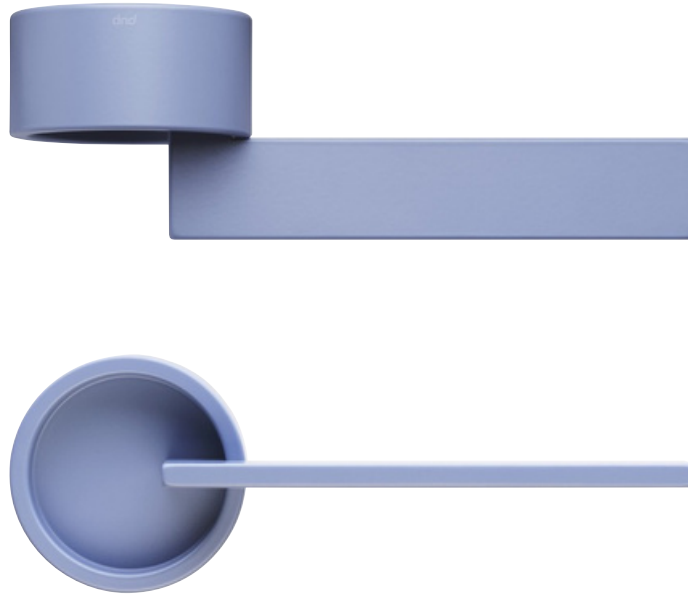

Due segni grafici essenziali, una linea e un cerchio che si intersecano in maniera centrale e simmetrica.

Two essential graphic signs, a line and a circle that intersect in a central and symmetrical way.

TIMELESS



TIMELESS

design:
Marco Pisati

Alluminio
Aluminium

made in italy

® TL01



ARO
Oro satinato
Satin gold



ABR
Bronzo
Bronze



ASV
Silver
Silver



ABN
Bianco
White



AGO
Giallo oliva
Yellow olive



AVP
Violetto pastello
Pastel violet



ABC
Blu colomba
Blue dove



ABT
Turchese
Turquoise



ANE
Nero
Blac
k

vis TL22V
martellina DK
DK window handle



TL39
pomolo Ø60 mm
Ø60 mm knob



TL70
pomolino per mobile Ø30 mm
Ø30 mm furniture knob



RDN50+A
nottolino
turn & release



ISABELLA

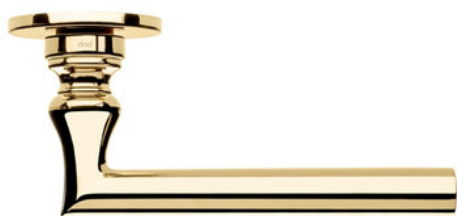

Un cilindro e lievi
modanature, tra
forme classiche e
volumi moderni.

A cylinder and
slight moldings, betwe-
en classical forms and
modern volumes.

ISABELLA

design:
Marco Pisati

Ottone
Brass

made in italy

FINE IS40



PVD-BG | forte®
Oro antico lucido
Antique bright gold



PVD-SG | forte®
Oro antico satinato
Antique satin gold



PVD-SH | forte®
Oro champagne satinato
Champagne satin gold



PVN | forte®
Nickel lucido
Bright nickel



PGS | forte®
Grafite satinato
Satin graphite



BSO
Bronzo sabbato opaco
Matt sandblasted bronze



OGH
Bronzo satinato opaco
Matt satin bronze



OC
Cromo lucido
Polished chrome

U



OCS
Cromo satinato
Satin chrome

VIS IS22V
martellina DK
DK window handle



U IS22U
martellina DK Unico
Unico DK window handle



IS21M
mar tellina
window handle



LUCREZIA

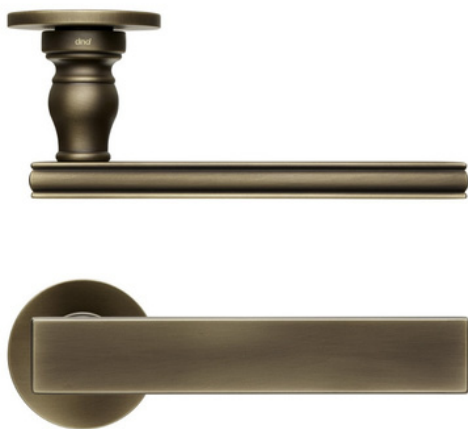

Rimandi rinascimentali nel bel modellato dello stelo, a cui si aggiunge il disegno dell'impugnatura: una forma rettangolare alleggerita da un'elegante modanatura a caratterizzarne il bordo.

Renaissance references in the fine shaping of the stem, joined by the design of the grip: a rectangular form lightened by elegant shaped borders.

LUCREZIA

design:
Marco Pisati

Ottone
Brass

made in italy

LT40



PVD-BG | forte®
Oro antico lucido
Antique bright gold



PVD-SG | forte®
Oro antico satinato
Antique satin gold



PVN | forte®
Nickel lucido
Bright nickel



PGS | forte®
Grafite satinato
Satin graphite



BSO
Bronzo sabbato opaco
Matt sandblasted bronze



OGH
Bronzo satinato opaco
Matt satin bronze



OCS
Cromo satinato
Satin chrome

LT30V
martellina DK
DK window handle



LT35
pomolo
knob



LT27
maniglia
e pull
handle

LT70
pomolino per mobile
furniture knob



LT80
accessori per mobili
furniture accessories

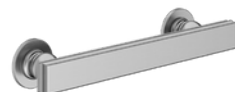

LUCREZIA 02



LUCREZIA 02

design:
Marco Pisati

Ottone
Brass

made in italy

FINE LT41



PVD-BG | forte®
Oro antico lucido
Antique bright gold



PVD-SG | forte®
Oro antico satinato
Antique satin gold



PVN | forte®
Nickel lucido
Bright nickel



PGS | forte®
Grafite satinato
Satin graphite



BSO
Bronzo sabbato opaco
Matt sandblasted bronze



OGH
Bronzo satinato opaco
Matt satin bronze



OCS
Cromo satinato
Satin chrome

R LT31
martellina DK
DK window handle



LT10
maniglia su placca
handle on plate



LT35
pomolo
knob



LT27
maniglia
e pull
handle



ELEONORA

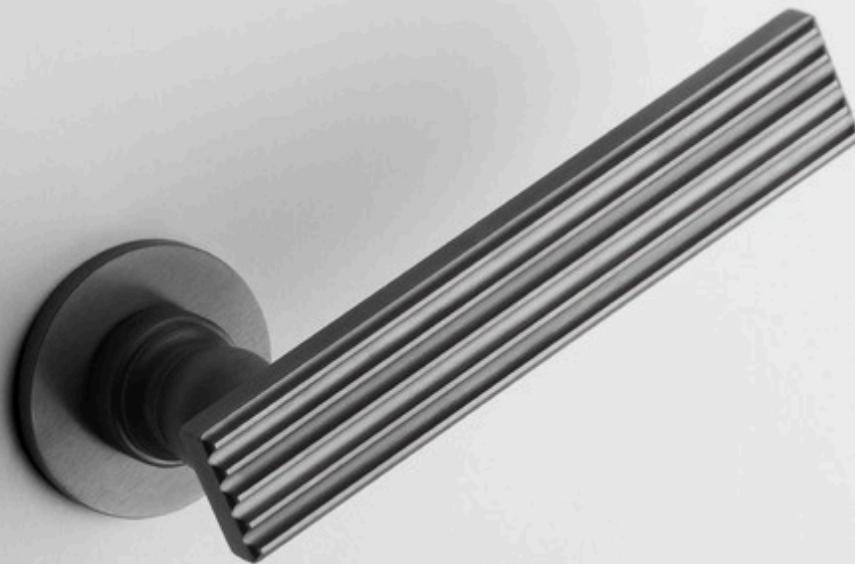

Sottili scanalature per l'impugnatura, in omaggio allo stile ionico; e un modellato morbido ma rigoroso per lo stelo: una maniglia che guarda agli stili della storia, in equilibrio tra antica Grecia e Rinascimento.

Subtle grooves in the handle, redolent of the Ionic style, along with a soft yet rigorous shape for the stem: a handle that draws upon styles from throughout history, carefully balanced between Ancient Greece and the Renaissance.

ELEONORA

design:
Marco Pisati

Ottone
Brass

made in italy

EL40



PVD-BG | forte®
Oro antico lucido
Antique bright gold



PVD-SG | forte®
Oro antico satinato
Antique satin gold



PVN | forte®
Nickel lucido
Bright nickel



PGS | forte®
Grafite satinato
Satin graphite



BSO
Bronzo sabbato opaco
Matt sandblasted bronze



OGH
Bronzo satinato opaco
Matt satin bronze



OCS
Cromo satinato
Satin chrome

EL22V
martellina DK
DK window handle



EL22U
martellina DK Unico
Unico DK window handle



EL29
maniglia
e pull
handle

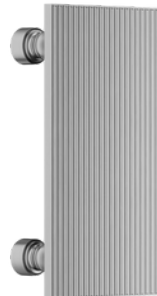

EL31
maniglia
e pull
handle

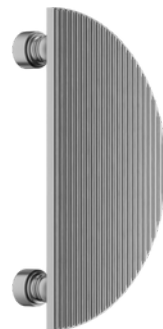

ELEONORA 02



ELEONORA 02

design:
Marco Pisati

Ottone
Brass

made in italy

FINE EL41



PVD-BG | forte®
Oro antico lucido
Antique bright gold



PVD-SG | forte®
Oro antico satinato
Antique satin gold



PVN | forte®
Nickel lucido
Bright nickel



PGS | forte®
Grafite satinato
Satin graphite



BSO
Bronzo sabbato opaco
Matt sandblasted bronze



OGH
Bronzo satinato opaco
Matt satin bronze



OCS
Cromo satinato
Satin chrome

R EL25
martellina DK
DK window handle



EL10
maniglia su placca
handle on plate



EL27
maniglia
e pull
handle



Luca Nichetto



Designer originario di Venezia, è attivo a livello internazionale ed è specializzato in design industriale, design del prodotto e consulenza. I suoi due studi si trovano a Venezia – dal 2006 – e in Svezia, a Stoccolma – dal 2011. Ha ricevuto numerosi premi internazionali per i suoi progetti, che spaziano tra prodotti, mobili e accessori, oltre a integrare architettura e design espositivo. Tra i marchi dei suoi progetti Arflex, Cassina, De La Espada, Foscari, Hermès, Molteni & C, Tubes, Venini, Wittmann.

Designer originally from Venice, he works on an international basis and specialises in industrial design, product design and design consultancy. His two studios are based in Italy in Venice – from 2006 – and in Sweden – from 2011. He has been awarded numerous international design awards for his projects, which range across products, furniture and accessories, as well as incorporating architecture and exhibition design. Among the brands of his projects, Arflex, Cassina, De La Espada, Foscari, Hermès, Molteni & C, Tubes, Venini, Wittmann.

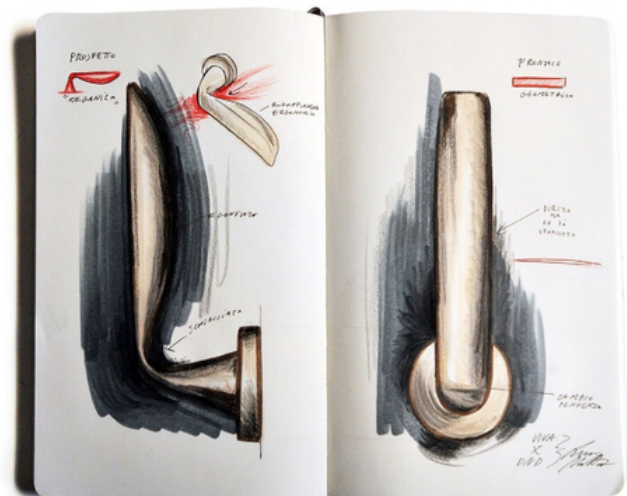

Viva!
Disegni della maniglia di /
Handle sketches by
Luca Nichetto

VIVA!



Una maniglia che nasce dalla fusione dei fondamentali aspetti ergonomici con la sobrietà dell'impatto visivo. Viva! presenta un aspetto diverso a seconda del punto di osservazione, con tratti lineari o morbidi e sinuosi a caratterizzarla.

A handle based on the fusion of fundamental ergonomic aspects with understated visual impact. Viva! looks different from various vantage points, with linear or soft, sinuous features.

VIVA!



VIVA!

design:
Luca Nichetto

Ottone
Brass

made in italy

FINE VV40



PVD-BG | forte®
Oro antico lucido
Antique bright gold



PVD-SG | forte®
Oro antico satinato
Antique satin gold



PVN | forte®
Nickel lucido
Bright nickel



PGS | forte®
Grafite satinato
Satin graphite



BSO
Bronzo sabbiato opaco
Matt sandblasted bronze



OGH
Bronzo satinato opaco
Matt satin bronze



OCS
Cromo satinato
Satin chrome



ONO
Nero
Black

VIS VV22V
martellina DK
DK window handle



U VV22U
martellina DK Unico
Unico DK window handle



Giulio Iacchetti



Vive e lavora a Milano, dove si occupa di industrial design dal 1992. Tra le aziende con cui collabora: Alessi, Artemide, Bvlgari, Coop, Danese Milano, Foscarini, Nava, Magis. È direttore artistico di Abet Laminati, Dnd, Montbook, Ebanisteria Meccanica. Da sempre attento all'evoluzione del rapporto tra realtà artigiana e design, nel 2012 fonda il marchio Internoitaliano. Tra i suoi caratteri distintivi ci sono la ricerca e la definizione di nuove tipologie oggettuali. Nel 2009 la Triennale di Milano ha ospitato una sua mostra personale intitolata "Giulio Iacchetti. Oggetti disobbedienti". È stato premiato con due premi ADI Compasso d'Oro (2001, posata "Moscardino"; 2014, tombini serie "Sfera") e ha ricevuto diversi riconoscimenti internazionali.

He lives and works in Milan, where he has been involved in industrial design since 1992. Among the companies he collaborates with are: Alessi, Artemide, Bvlgari, Coop, Danese Milano, Foscarini, Nava, Magis.

He is the artistic director of Abet Laminati, Dnd, Montbook, Ebanisteria Meccanica.

Always attentive to the evolution of the relationship between craftsmanship and design, he founded the brand Internoitaliano in 2012.

His distinctive features include research and the definition of new object typologies.

In 2009, the Triennale di Milano hosted a solo exhibition of his work entitled "Giulio Iacchetti. Oggetti disobbedienti". He has been awarded two ADI Compasso d'Oro awards (2001, "Moscardino" cutlery; 2014, "Sfera" series manhole covers) and has received several international awards.

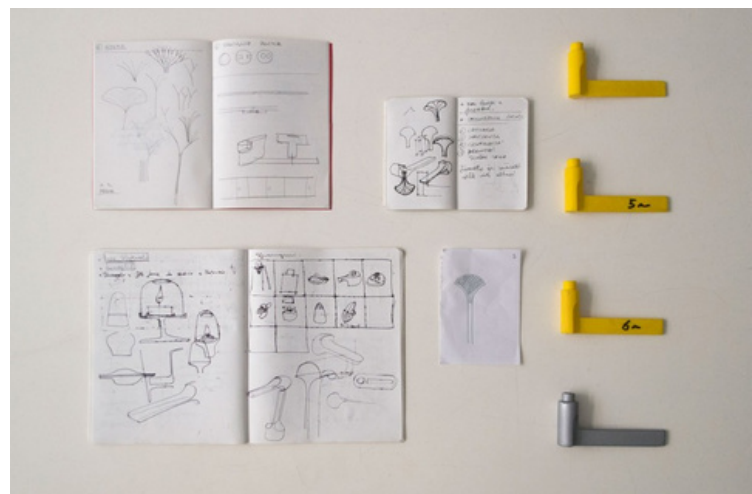

Ginkgo
Disegni della maniglia di /
Handle sketches by
Giulio Iacchetti

GINKGO



Una forma di ispirazione naturale, quale la bellissima foglia del Ginkgo, si fa struttura e decoro per una maniglia che nasce in due diverse versioni.

A form based on nature, the special, unique shape of a Ginkgo leaf, becomes the structure and decoration of a handle that is made in two different versions.

GINKGO



GINKGO

design:
Giulio Iacchetti
made in italy

Ottone
Brass

FINE GK40



PVD-BG | forte®
Oro antico lucido
Antique bright gold



PVD-SG | forte®
Oro antico satinato
Antique satin gold



PVD-SH | forte®
Oro champagne satinato
Champagne satin gold



PVD-SB | forte®
Bronzo satinato
Satin bronze



PVN | forte®
Nickel lucido
Bright nickel



PGS | forte®
Grafite satinato
Satin graphite



OC
Cromo lucido
Polished chrome



OCS
Cromo satinato
Satin chrome

U



ONO
Nero
Black

VIS GK22V
martellina DK
DK window handle



U GK22U
martellina DK Unico
Unico DK window handle



GK21M
mar tellina
window handle



GK27
maniglia
e pull
handle



GINKGO BILOBA



Good Design Awards
2017

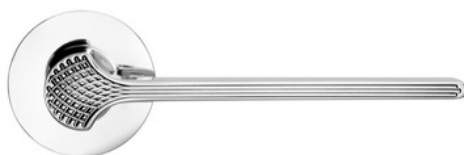

Ginkgo Biloba, la versione della maniglia Ginkgo con l'incisione in superficie, è un ulteriore rimando metaforico alle venature della foglia.

Ginkgo Biloba, the version of the Ginkgo handle with the decorative surface engraving, is a further metaphorical reminder of the veins of the leaf.

GINKGO BILOBA

design:
Giulio Iacchetti
made in italy

Ottone
Brass

GB40



PVD-BG | forte®
Oro antico lucido
Antique bright gold



PVD-SG | forte®
Oro antico satinato
Antique satin gold



PVD-SH | forte®
Oro champagne satinato
Champagne satin gold



PVD-SB | forte®
Bronzo satinato
Satin bronze



PVN | forte®
Nickel lucido
Bright nickel



PGS | forte®
Grafite satinato
Satin graphite



OC
Cromo lucido
Polished chrome



OCS
Cromo satinato
Satin chrome

U



ONO
Nero
Black

GB22V
martellina DK
DK window handle



GB22U
martellina DK Unico
Unico DK window handle



GB21M
mar tellina
window handle



GB27
maniglia
e pull
handle



FREELY



FREELY

design:
Giulio Iacchetti

Alluminio
Aluminium

made in italy

FR01



ACS
Cromo satinato
Satin chrome



ANE
Nero
Black

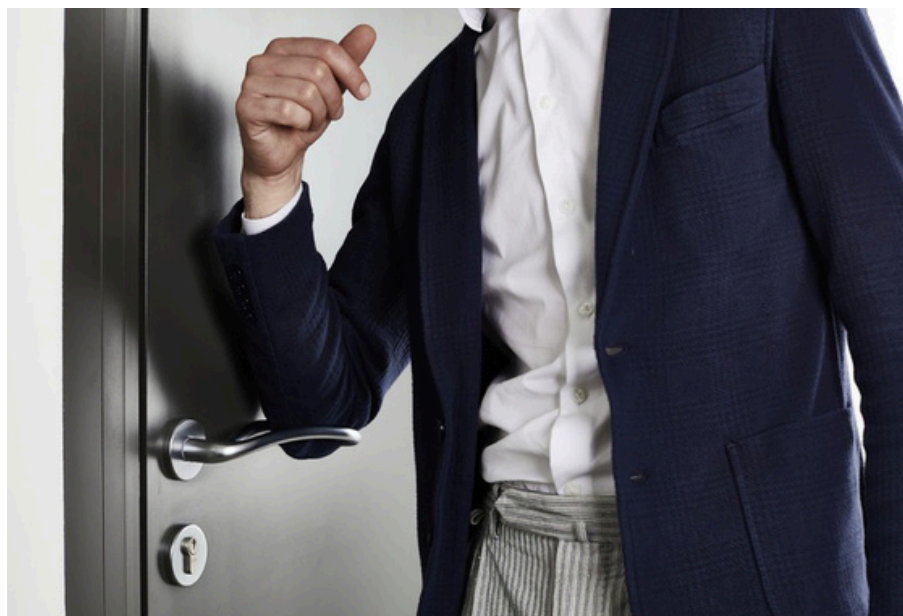

Odo Fioravanti



Dal 2003, con base a Milano, lavora come industrial designer sperimentando anche la grafica e l'exhibition design. I suoi oggetti sono stati esposti in molte mostre internazionali e nel 2010 il Design Museum della Triennale di Milano ha dedicato al suo lavoro la personale "Industrious Design". Nel 2011 ha vinto il Compasso d'Oro ADI con la sedia in legno Frida di Pedrali. Tra i suoi clienti, Alpi, Flou, Fontana Arte, Foscari, Land Rover, Maison 203, Normann Copenhagen, Pedrali, Toshiba, Vibram, Victorinox.

Since 2003, based in Milan, he has been working as an industrial designer, while experimenting also with graphic and exhibition design. His objects have been shown in many international exhibitions and in 2010 the Design Museum of the Triennale di Milano dedicated to his work the solo exhibition "Industrious Design". In 2011 he won the Compasso d'Oro ADI award with the Frida wooden chair by Pedrali. Among his clients, Alpi, Flou, Fontana Arte, Foscari, Land Rover, Maison 203, Normann Copenhagen, Pedrali, Toshiba, Vibram, Victorinox.

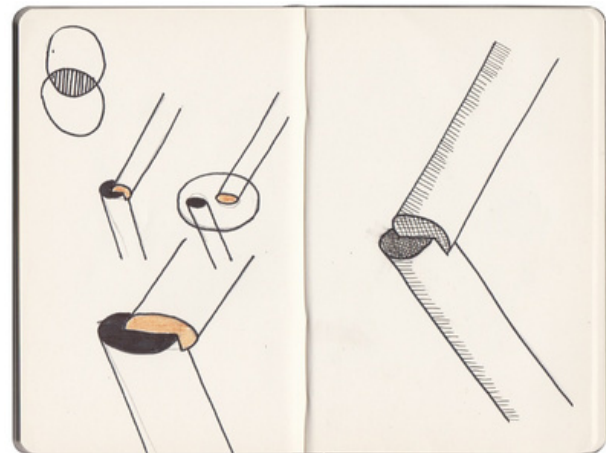

Boole
Disegni della maniglia di /
Handle sketches by
Odo Fioravanti

BOOLE



Due cilindri si incontrano e si intersecano con il leggero slittamento di uno rispetto all'altro, nella condivisione di una piccola, comune porzione di materia.

Two cylinders meet and intersect with a slight shift, sharing a small portion of material.

BOOLE



BOOLE

design:
Odo Fioravanti

Ottone
Brass

made in italy

BE40



PVD-SG | forte®
Oro antico satinato
Antique satin gold



PGS | forte®
Grafite satinato
Satin graphite



OCS
Cromo satinato
Satin chrome



ONO
Nero
Black

BE22V
martellina DK
DK window handle



BE22U
martellina DK Unico
Unico DK window handle



SAFETY



SAFETY

design:
Enrico Martini

Ottone
Brass

made in italy

SA40



PVD-SG | forte®
Oro antico satinato
Antique satin gold

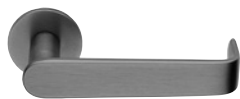

PGS | forte®
Grafite satinato
Satin graphite



OCS
Cromo satinato
Satin chrome



ONO
Nero
Black

SA22V
martellina DK
DK window handle



Maurizio Varratta



Nato a Genova, si laurea in architettura nel 1981 e dal 1983 al 1999 lavora con lo studio Renzo Piano Building Workshop. Nel 1999 apre il suo studio e comincia a partecipare a numerosi concorsi internazionali, mentre svolge l'attività di professore in diverse università (Politecnico di Torino, La Sapienza di Roma, Carleton University di Ottawa). I lavori dello studio spaziano dalla progettazione architettonica generale al design e allo space planning, con l'applicazione dei principi della sostenibilità ambientale e della qualità degli spazi.

Born in Genoa, he graduated in architecture in 1981 and worked with the Renzo Piano Building Workshop from 1983 to 1999. In 1999 he opened his own firm and began to participate in numerous international competitions, while working as a professor in various universities (Politecnico di Torino, La Sapienza di Roma, Carleton University in Ottawa). The studio's work ranges from architectural design to industrial design and space planning, applying the principles of environmental sustainability and quality of space.

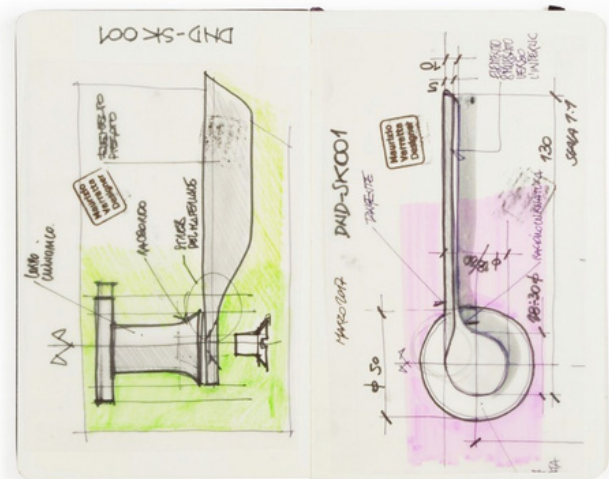

Levante
Disegni della maniglia di /
Handle sketches by
Maurizio Varratta

LEVANTE

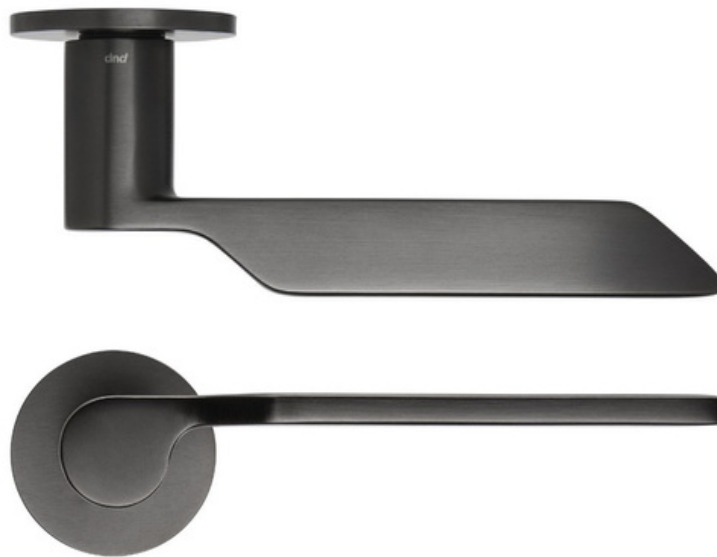

L'essenzialità di una
forma asciutta e
semplice, caratterizza
un oggetto il cui
disegno si identifica
con la sua funzione.

The essence of a
terse, simple form,
an object whose
design would be
identified with its
function.

LEVANTE



LEVANTE

design:
Maurizio Varratta

Ottone
Brass

made in italy

FINE LE40



PVD-SG | forte®
Oro antico satinato
Antique satin gold



PVD-SB | forte®
Bronzo satinato
Satin bronze



PGS | forte®
Grafite satinato
Satin graphite



OCS
Cromo satinato
Satin chrome

U



ONO
Nero
Black

VIS LE22V
martellina DK
DK window handle



U LE22U
martellina DK Unico
Unico DK window handle



Stefano Boeri Architetti



Stefano Boeri, architetto e urbanista, è professore ordinario di Urbanistica al Politecnico di Milano e Direttore del Future City Lab alla Tongji Università di Shanghai.

Architetto del Bosco Verticale (Milano, 2014), il lavoro di Stefano Boeri spazia dalle visioni urbane al design, con una costante attenzione alle implicazioni geopolitiche e ambientali dei fenomeni urbani.

Tra i principali attori del dibattito sul cambiamento climatico nel campo dell'architettura internazionale, Stefano Boeri è noto anche per le sue ricerche sulla forestazione urbana e l'implementazione della biodiversità nelle città.

Il suo approccio progettuale Green Obsession ha ricevuto il premio UN SDG Action Award nella categoria "Inspire" per il sostegno all'implementazione dei 17 Obiettivi di Sviluppo Sostenibile delle Nazioni Unite.

Stefano Boeri, architect and urban planner, is Full Professor of Urban Planning at Politecnico di Milano and Director of the Future City Lab at Tongji University in Shanghai.

Architect of the Bosco Verticale (Milan, 2014) Stefano Boeri's work ranges from urban visions to design, with a constant focus on the geopolitical and environmental implications of urban phenomena.

Among the main actors in the climate change debate in the field of international architecture, Stefano Boeri is known for his researches on urban forestry and biodiversity implementation in cities. His design approach Green Obsession received the UN SDG Action Award in the "Inspire" category for supporting the implementation of the 17 UN Sustainable Development Goals.



DUE
Disegni della maniglia di /
Handle sketches by
Stefano Boeri Architetti

DUE



Una soluzione
dalla forza plastica
essenziale:
la sua figura è resa
primigenia attraverso
la trasformazione
dei due tradizionali
elementi funzionali,
l'impugnatura e
la rosetta, in una
coppia di sottili
parallelepipedi
per fettamente
uguali tra loro.

A solution of
essential sculptural
force: the figure
becomes primeval
through the
transformation of
the two traditional
functional elements,
the grip and the
plate, into a pair of
slender
parallelepipeds,
perfectly equal.

DUE



DUE

design:
Stefano Boeri Architetti

Ottone
Brass

made in italy

DU10



PVD-SG | forte®
Oro antico satinato
Antique satin gold



PVD-SB | forte®
Bronzo satinato
Satin bronze



PGS | forte®
Grafite satinato
Satin graphite



OCS
Cromo satinato
Satin chrome



ONO
Nero
Black

R DU25
martellina DK
DK window handle



DUE



DUE

design:
Stefano Boeri Architetti

Ottone
Brass

made in italy

DU11



PVD-SG | forte®
Oro antico satinato
Antique satin gold



PVD-SB | forte®
Bronzo satinato
Satin bronze



PGS | forte®
Grafite satinato
Satin graphite



OCS
Cromo satinato
Satin chrome



ONO
Nero
Black

R DU25
martellina DK
DK window handle



DUE

design:
Stefano Boeri Architetti
made in italy

Ottone
Brass

DU40



PVD-SG | forte®
Oro antico satinato
Antique satin gold



PVD-SB | forte®
Bronzo satinato
Satin bronze



PGS | forte®
Grafite satinato
Satin graphite



OCS
Cromo satinato
Satin chrome



ONO
Nero
Black

DU22V
martellina DK
DK window handle



DU22U
martellina DK Unico
Unico DK window handle



DUE

design:
Stefano Boeri Architetti

Ottone
Brass

made in italy

FINE DU41



PVD-SG | forte®
Oro antico satinato
Antique satin gold



PVD-SB | forte®
Bronzo satinato
Satin bronze



PGS | forte®
Grafite satinato
Satin graphite



OCS
Cromo satinato
Satin chrome



ONO
Nero
Black

R DU25
martellina DK
DK window handle



Jaime Hayon



Artista-designer originario di Madrid, ha aperto il suo studio a Valencia nel 2010. Con uffici in Spagna, Italia e Giappone, progetta per Fritz Hansen, Bosa, Cassina, BD Barcelona, Wittmann, Magis, Ceccotti, &Tradition, Baccarat, Paola C, Bisazza, LLadro, Vicarbe, Arflex, Nani Marquina, Vista Alegre, Parachilna. Ha vinto numerosi premi internazionali ed è stato incluso da Wallpaper Magazine nella lista "Top 100", riconosciuto come uno dei creatori più influenti dell'ultimo decennio.

Artist-designer originally from Madrid, opened his studio in Valencia in 2010. With offices in Spain, Italy and Japan, he designs for Fritz Hansen, Bosa, Cassina, BD Barcelona, Wittmann, Magis, Ceccotti, &Tradition, Baccarat, Paola C, Bisazza, LLadro, Vicarbe, Arflex, Nani Marquina, Vista Alegre, Parachilna. He has won numerous awards and he has been included by Wallpaper Magazine in its "Top 100" list, recognised by the magazine as one of the most influential creators of the last decade.

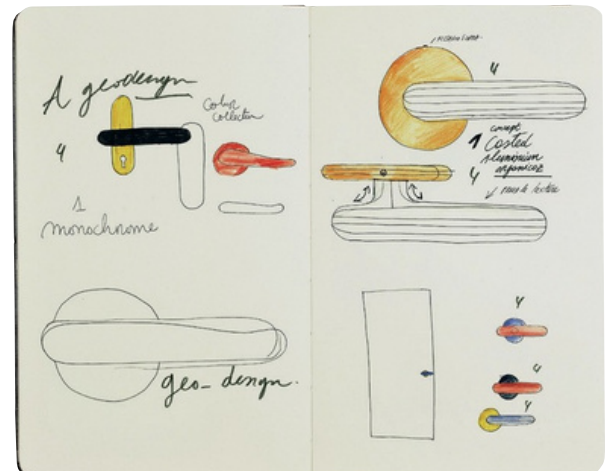

Zeppelin
Disegni della maniglia di /
Handle sketches by
Jaime Hayon

ZEPPELIN



Volumi marcati e arrotondati come rimando formale – e decorativo – ai dirigibili Zeppelin dell'inizio del 1900, per una maniglia contemporanea, dalla sapiente realizzazione tecnica.

Pronounced rounded volumes as a formal – and decorative – reference to the Zeppelin airships of the early 1900s, for a contemporary handle made with great technical prowess.

ZEPPELIN



ZEPPELIN

design:
Jaime Hayon

Ottone
Brass

made in italy

vis ZP12



PVD-BG | forte®
Oro antico lucido
Antique bright gold



PVD-SG | forte®
Oro antico satinato
Antique satin gold



PVN | forte®
Nickel lucido
Bright nickel



PGS | forte®
Grafite satinato
Satin graphite



OC
Cromo lucido
Polished chrome



OCS
Cromo satinato
Satin chrome



OVE
Verde
Green



ONO
Nero
Black

vis ZP22V
martellina DK
DK window handle



u ZP22U
martellina DK Unico
Unico DK window handle



ZP27
maniglia
pull
handle

967arch



967arch progetta da 25 anni architettura, interni e design di prodotto per aziende, clienti privati e pubblici. Fondato a Milano da Cesare Chichi e Stefano Maestri, lo studio si avvale della competenza di architetti e designer, coprendo diverse scale progettuali. Ogni proposta si basa su una matrice narrativa, intesa come supporto logico a ogni scelta stilistica e di identità. Semplicità, sobrietà e ironia sono il filo conduttore di tutti i lavori, in cui la cura dei dettagli e la ricerca di nuove soluzioni caratterizzano lo spirito progettuale nei settori terziario, industriale, residenziale e ricettivo. Lo studio ha realizzato edifici e spazi di lavoro per aziende come Accenture, Google, Petronas, Campari, Ferrero, Cisco, WPP, Amplifon, Fc Internazionale e Loro Piana. Collabora inoltre con marchi quali Davide Groppi, Dieffebi, Dnd, Las, MDF Italia, Poltrona Frau, Ritzwell, Saba, True Design e Molto Luce.

967arch has been designing architecture, interior, product design for companies, and private and public clients for over twenty years. Founded in Milan by Cesare Chichi and Stefano Maestri, the studio makes use of the expertise of architects and designers covering the different scales of the project. Each proposal is based on the matrix of the story, intended as logical support for every stylistic and identity choice. Simplicity, sobriety, and irony are the leitmotif of all the works where attention to detail and the search for new solutions characterize the spirit of the project in the tertiary, industrial, and residential sectors. The studio has created buildings and workspaces for Accenture, HP, Google, Petronas, Campari, Ferrero, Cisco, WPP, American Express, Amplifon, Fc Internazionale, Loro Piana, Kantar, Dieffebi, Davide Groppi. He designs products for brands such as Davide Groppi, Dieffebi, DND, Las, MDF Italia, Poltrona Frau, Ritzwell, Saba, True design, and Zumtobel.

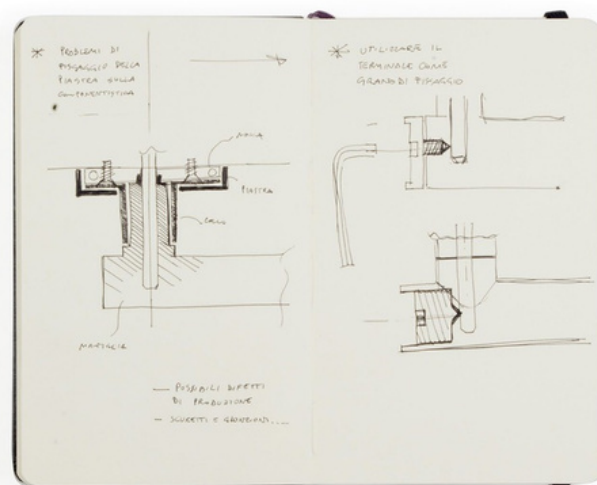

Blend
Disegni della maniglia di /
Handle sketches by
967arch

BLEND



Una maniglia nata dalla volontà di combinare forme elementari, cilindro e rettangolo, nella ricerca di un equilibrio complessivo ma soprattutto di una immediata e percettiva iconicità.

A handle based on the urge to combine basic forms, a cylinder and a rectangle, in pursuit of an overall balance and above all an immediate perceptive impact.

BLEND



BLEND

design:
967arch

Ottone
Brass

made in italy

BN10/R



PVD-SG | forte®
Oro antico satinato
Antique satin gold



PVD-SB | forte®
Bronzo satinato
Satin bronze



PGS | forte®
Grafite satinato
Satin graphite



OCS
Cromo satinato
Satin chrome



BNL
Bianco lucido
Bright white



ONO
Nero
Black

R BN25
martellina DK
DK window handle



BN10
maniglia su placca
handle on plate



BLEND

design:
967arch
made in italy

Ottone
Brass

BN40



PVD-SG | forte®
Oro antico satinato
Antique satin gold



PVD-SB | forte®
Bronzo satinato
Satin bronze



PGS | forte®
Grafite satinato
Satin graphite



OCS
Cromo satinato
Satin chrome



BNL
Bianco lucido
Bright white



ONO
Nero
Black

BN22U
martellina DK Unico
Unico DK window handle



BLEND 02

design:
967arch

made in italy

Ottone
Brass

FINE BN41



PVD-SG | forte®
Oro antico satinato
Antique satin gold



PVD-SB | forte®
Bronzo satinato
Satin bronze



PGS | forte®
Grafite satinato
Satin graphite



OCS
Cromo satinato
Satin chrome



BNL
Bianco lucido
Bright white



ONO
Nero
Black

R **BN25**
martellina DK
DK window handle



BN10
maniglia su placca
handle on plate



BLEND AG



BLEND AG

design:
967arch

Alluminio
Aluminium

made in italy

BG40



ARO
Oro satinato
Satin gold



ABR
Bronzo
Bronze



ASV
Silver
Silver



ABN
Bianco
White

U



ANE
Nero
Black

BG22V
martellina DK
DK window handle



BG22U
martellina DK Unico
Unico DK window handle



Cino Zucchi



Nato a Milano, Cino Zucchi si è laureato in architettura al M.I.T. di Boston e al Politecnico di Milano. È autore di articoli e libri di teoria architettonica. Insieme allo studio CZA ha progettato e realizzato molti progetti: tra i più noti, quelli della ex Junghans a Venezia, dell'ex Alfa Romeo – Portello Nord e della Corte Verde a Milano; il master plan per Keski Pasila a Helsinki, la nuova sede Lavazza (TO), gli HQ Salewa (BZ).

Born in Milan, Cino Zucchi has earned degrees in Architectural Design at M.I.T. and at Politecnico di Milano. He is author of several articles and books on architectural and urban theory. With his studio CZA, he has designed and completed a number of projects, including the former Junghans factory site in Venice; the former Alfa Romeo-Portello Nord area and the Corte Verde in Milan; the Keski-Pasila master plan in Helsinki; the Lavazza HQ (TO); and the Salewa HQ (BZ).

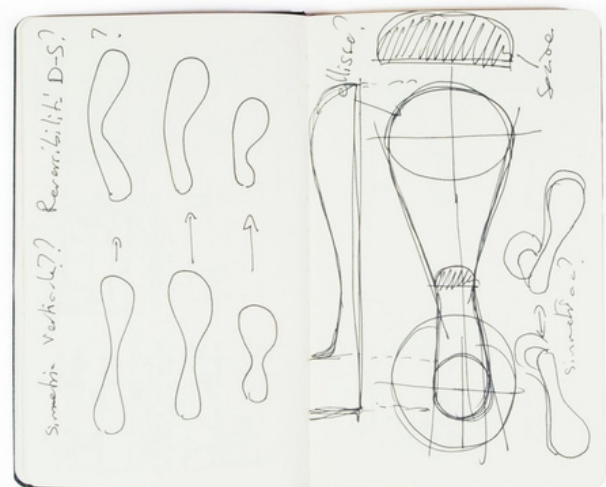

Drop
Disegni della maniglia di /
Handle sketches by
Cino Zucchi

DROP



Una maniglia dalle linee morbide e affabili, in cui l'ottone si lascia apprezzare nella sua forma migliore.

A door handle featuring a soft and affable shape, in which brass conveys its allure thanks to the best possible form.

DROP



DROP

design:
Cino Zucchi
made in italy

Ottone
Brass

DP40



PVD-SG | forte®
Oro antico satinato
Antique satin gold



PGS | forte®
Grafite satinato
Satin graphite



OCS
Cromo satinato
Satin chrome



ONO
Nero
Black

DP22V
martellina DK
DK window handle



DP22U
martellina DK Unico
Unico DK window handle



LUXURY

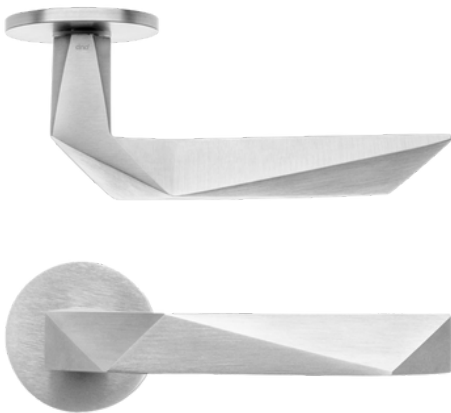
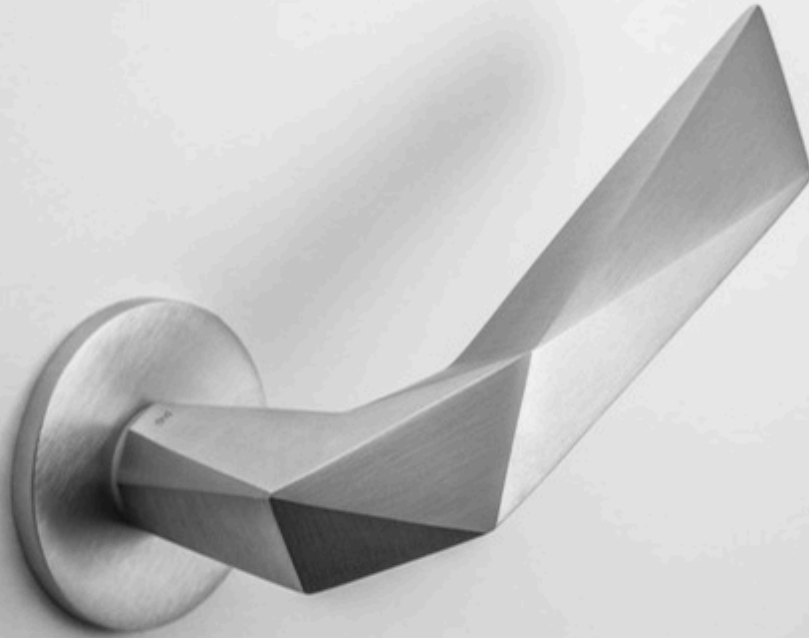

Geometrie sfaccettate e tagli netti nella materia rimandano a celebri episodi dell'architettura contemporanea.

Faceted geometry and clean cuts in the material evoke famous episodes of contemporary architecture.

LUXURY

design:
Mauro Ronchi
made in italy

Ottone
Brass

FINE LU40



PVD-BG | forte®
Oro antico lucido
Antique bright gold



PVD-SG | forte®
Oro antico satinato
Antique satin gold



PGS | forte®
Grafite satinato
Satin graphite



OGH
Bronzo satinato opaco
Matt satin bronze



OC
Cromo lucido
Polished chrome



OCS
Cromo satinato
Satin chrome



U
ONO
Nero
Black

VIS LU22V
martellina DK
DK window handle



U LU22U
martellina DK Unico
Unico DK window handle



LU21M
mar tellina
window handle



LU27
maniglia
e pull
handle



LUXURY 02

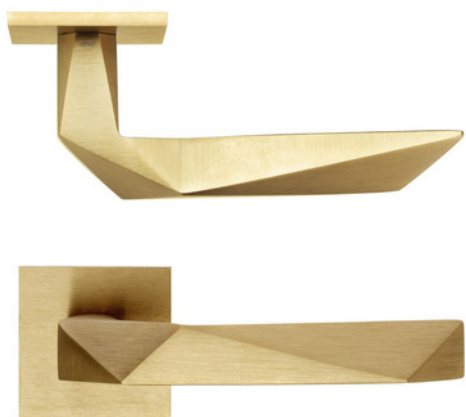
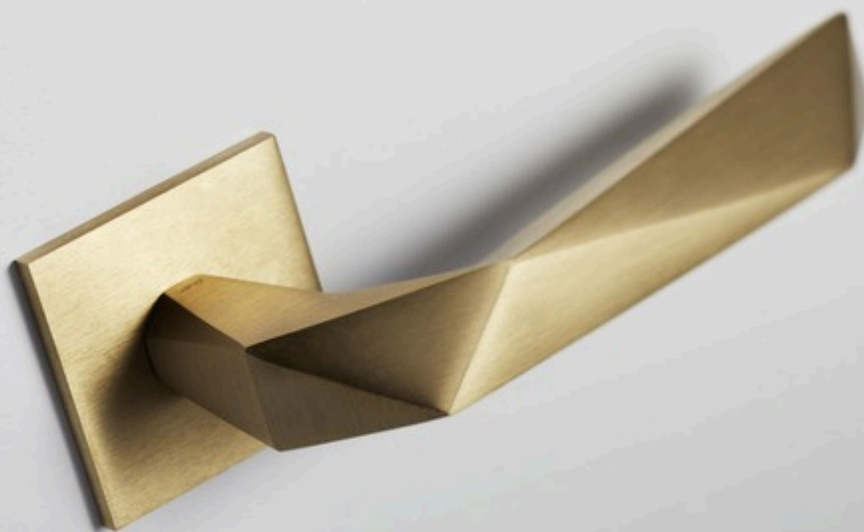

Geometrie sfaccettate e tagli netti nella materia rimandano a celebri episodi dell'architettura contemporanea.

Faceted geometry and clean cuts in the material evoke famous episodes of contemporary architecture.

LUXURY 02

design:
Mauro Ronchi

Ottone
Brass

made in italy

FINE LU41



PVD-BG | forte®
Oro antico lucido
Antique bright gold



PVD-SG | forte®
Oro antico satinato
Antique satin gold

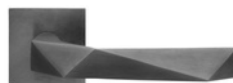

PGS | forte®
Grafite satinato
Satin graphite



OGH
Bronzo satinato opaco
Matt satin bronze



OC
Cromo lucido
Polished chrome



OCS
Cromo satinato
Satin chrome



ONO
Nero
Black

R LU25
martellina DK
DK window handle



LU24M
mar tellina
window handle



LU27
maniglia
e pull
handle



Inga Sempé



Nata a Parigi, nel 2000 è stata borsista a Villa Medici, presso l'Académie de France di Roma e, nello stesso anno, ha aperto il suo studio parigino. Le sue prime collaborazioni sono state con Edra e Cappellini. Oggi lavora con diverse aziende francesi, scandinave e italiane, tra le quali HAY, Ligne Roset, Wästberg, Magis, Alessi, Luceplan, Mutina, Crane, Rørros, Moustache, Svenskt Tenn, Gärnsås. Nel 2024 ha tenuto una mostra personale alla Triennale di Milano intitolata "La Casa Imperfetta".

Born in Paris, she was a fellow at Villa Medici in 2000, at the Académie de France in Rome and opened her Paris studio in the same year. Her first collaborations were with Edra and Cappellini. Today she works with several French, Scandinavian and Italian companies, including HAY, Ligne Roset, Wästberg, Magis, Alessi, Luceplan, Mutina, Crane, Rørros, Moustache, Svenskt Tenn, Gärnsås. In 2024, she held a solo exhibition at the Triennale di Milano entitled "La Casa Imperfetta" (The Imperfect House).

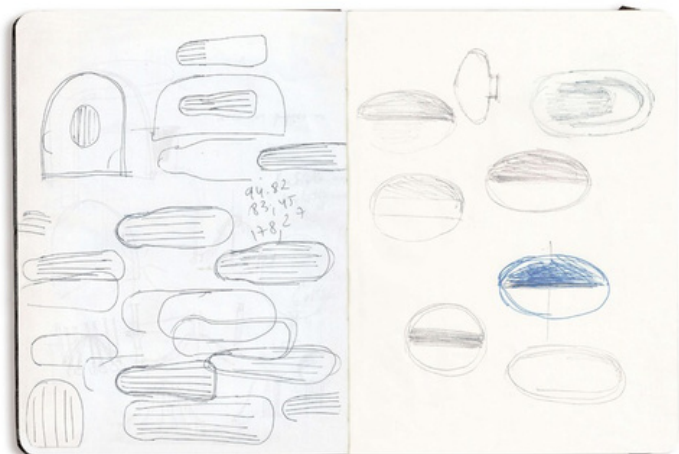

Madeleine
Disegni della maniglia di /
Handle sketches by
Inga Sempé

MADELEINE



Un omaggio alla dolce madeleine d'oltralpe in una piccola maniglia decorata che ne riprende la forma a conchiglia.

A tribute to the famous madeleine cakes from beyond the Alps, in a small decorated handle that replicates their seashell form.

MADELEINE

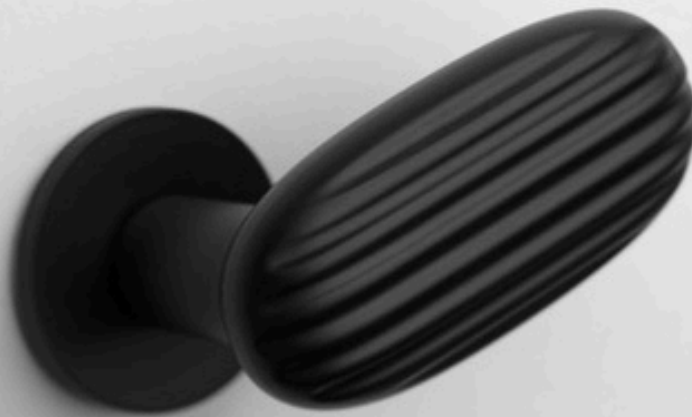

MADELEINE

design:
Inga Sempé
made in italy

Ottone
Brass

FINE MA40



PVD-BG | forte®
Oro antico lucido
Antique bright gold



PVD-SG | forte®
Oro antico satinato
Antique satin gold



PVN | forte®
Nickel lucido
Bright nickel



PGS | forte®
Grafite satinato
Satin graphite



OC
Cromo lucido
Polished chrome



OCS
Cromo satinato
Satin chrome



U
ONO
Nero
Black

VIS MA22V
martellina DK
DK window handle



U MA22U
martellina DK Unico
Unico DK window handle



INTAKE



Disegnata per il Museo Casa Enzo Ferrari di Modena, solida nella materia e plastica nella forma, è un omaggio al car design più attento.

Designed for the Enzo Ferrari Museum in Modena, solid in terms of material, sculptural in terms of form, in a tribute to the finest automotive design.

INTAKE

design:
Andrea Morgante

Ottone
Brass

made in italy

IN14



OC
Cromo lucido
Polished chrome



OBN
Bianco
White



ONO
Nero
Black

C-1918

ON DEMAND



Una maniglia – e una serie – d'autore caratterizzata dalla sapiente unione di acciaio e rame. Un progetto inedito, riscoperto e prodotto da Dnd con grande orgoglio.

A signature handle – and series – based on the felicitous combination of steel and copper. An original project, rediscovered and produced with great pride by Dnd.

C-1918

design:
Achille Castiglioni
Gianfranco Cavaglia

Acciaio inox AISI 316 + rame
AISI Stainless steel 316 + copper

made in italy

 **CC12**



L316 + R
AISI 316 lucido + inserto rame
PVD
AISI 316 polished + PVD copper
insert



S316 + R
AISI 316 satinato + inserto rame
PVD
AISI 316 satin + PVD copper
insert



L316 + N
AISI 316 lucido + inserto rame
nero
AISI 316 polished + copper
black insert



S316 + N
AISI 316 satinato + inserto rame
nero
AISI 316 satin + copper black
insert

CC22
martellina DK
DK window handle



SHORT



Linee morbide dall'appeal immediato. Una maniglia dal design compatto ed equilibrato, molto apprezzata per la sua versatilità di applicazione in termini di stile e finiture.

The immediate appeal of soft lines. A compact and balanced design defines this handle, very appreciated thanks to its versatility, both style and finishes.

SHORT

design:
Karim Rashid
made in italy

Ottone
Brass

SH40



PVD-SG | forte®
Oro antico satinato
Antique satin gold



PVD-SH | forte®
Oro champagne satinato
Champagne satin gold



PVD-SB | forte®
Bronzo satinato
Satin bronze



PGS | forte®
Grafite satinato
Satin graphite



BSO
Bronzo sabbato opaco
Matt sandblasted bronze



OCS
Cromo satinato
Satin chrome



AB
Bronzato
Antique bronze



OBN
Bianco
White

U



ONO
Nero
Black

SH22V
martellina DK
DK window handle



SH22U
martellina DK Unico
Unico DK window handle



SH21M
mar tellina
window handle



EDRA 02

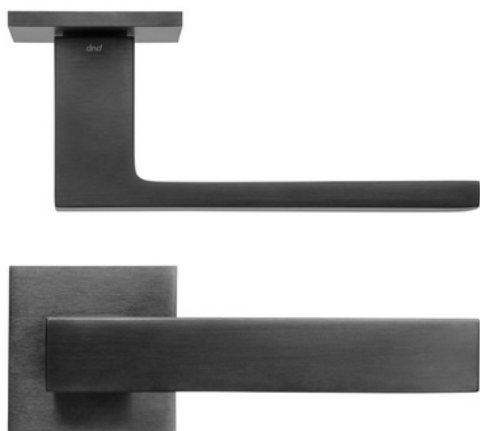

La forza di una forma
archetipica: l'idea
stessa di maniglia
si concretizza in
geometrie e volumi di
essenziale purezza.

The force of
archetypal form: the
idea of the handle
itself embodied by
geometric lines and
volumes of essential
purity.

EDRA 02

design:
Mauro Ronchi

Ottone
Brass

made in italy

FINE ED41



PVD-SG | forte®
Oro antico satinato
Antique satin gold



PVD-SH | forte®
Oro champagne satinato
Champagne satin gold



PVD-SB | forte®
Bronzo satinato
Satin bronze



PGS | forte®
Grafite satinato
Satin graphite



OGH
Bronzo satinato opaco
Matt satin bronze



OC
Cromo lucido
Polished chrome



OCS
Cromo satinato
Satin chrome



ONS
Nickel satinato
Satin nickel



ONO
Nero
Black

R ED25
martellina DK
DK window handle



ED26M
mar tellina
window handle



ED60
maniglione per alzante scorrevole
pull handle for lift sliding system



LO25
maniglia
e pull
handle



GINEVRA



GINEVRA

design:
Dnd technical division
made in italy

Ottone
Brass

R GI19



PVD-BG | forte®
Oro antico lucido
Antique bright gold



PVD-SG | forte®
Oro antico satinato
Antique satin gold



PVN | forte®
Nickel lucido
Bright nickel



PGS | forte®
Grafite satinato
Satin graphite



OGH
Bronzo satinato opaco
Matt satin bronze



OCS
Cromo satinato
Satin chrome

R GI25
martellina DK
DK window handle



GI10
maniglia su placca
handle on plate



FLUKE

ON DEMAND



Una forma dinamica che nasce dall'incontro di due volumi troncoconici contrapposti: il segno forte di un design riconoscibile e riconosciuto.

A dynamic form that arises from the meeting of two opposing cones: the vivid impact of a recognizable design.

FLUKE

design:
Karim Rashid
made in italy

Ottone
Brass

® **FK14**



PVD-SG | forte®
Oro antico satinato
Antique satin gold



OC
Cromo lucido
Polished chrome



OCS
Cromo satinato
Satin chrome

vis **FK22V**
martellina DK
DK window handle



ARETÈ 02



Geometrie sfaccettate e tagli netti nella materia rimandano a celebri episodi dell'architettura contemporanea.

A game of openness and fullness in a precise squared surface, lightened by small triangular cutouts for a decorative touch.

ARETÈ 02

design:
Mauro Ronchi
made in italy

Ottone
Brass

FINE AT41



PVD-SG | forte®
Oro antico satinato
Antique satin gold



PGS | forte®
Grafite satinato
Satin graphite



AB
Bronzato
Antique bronze



OCS
Cromo satinato
Satin chrome

R AT25
martellina DK
DK window handle



AT27
maniglia
e pull
handle



ARETÉ



ARETÈ

design:
Mauro Ronchi
made in italy

Ottone
Brass

FINE AT40



PVD-SG | forte®
Oro antico satinato
Antique satin gold



PGS | forte®
Grafite satinato
Satin graphite



AB
Bronzato
Antique bronze



OCS
Cromo satinato
Satin chrome

VIS AT22V
martellina DK
DK window handle



U AT22U
martellina DK Unico
Unico DK window handle



AT27
maniglia
e pull
handle



ARETÈ L

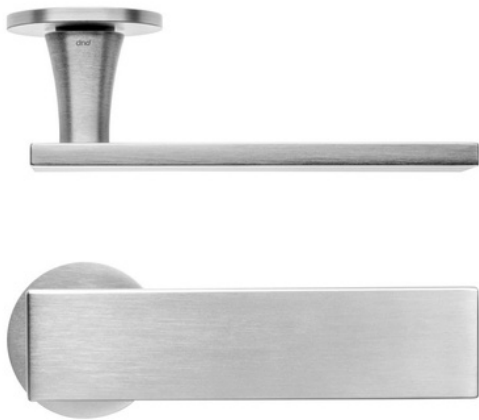

Il nitore di una
geometria classica
dal sapore
contemporaneo: una
maniglia che parla di
sostanziosa semplicità.

The clarity of classical
geometry with a
contemporary mood:
a handle that speaks
of sophisticated
simplicity.

ARETÈ L

design:
Mauro Ronchi
made in italy

Ottone
Brass

AL40



PVD-SG | forte®
Oro antico satinato
Antique satin gold



PGS | forte®
Grafite satinato
Satin graphite



AB
Bronzato
Antique bronze



OCS
Cromo satinato
Satin chrome

AL22V
martellina DK
DK window handle



AL22U
martellina DK Unico
Unico DK window handle



AL27
maniglia
e pull
handle



ARETÈ L 02



ARETÈ L 02

design:
Mauro Ronchi
made in italy

Ottone
Brass

FINE AL41



PVD-SG | forte®
Oro antico satinato
Antique satin gold



PGS | forte®
Grafite satinato
Satin graphite



AB
Bronzato
Antique bronze



OCS
Cromo satinato
Satin chrome

R AL25
martellina DK
DK window handle



AL27
maniglia
e pull
handle



CHANGE B 02

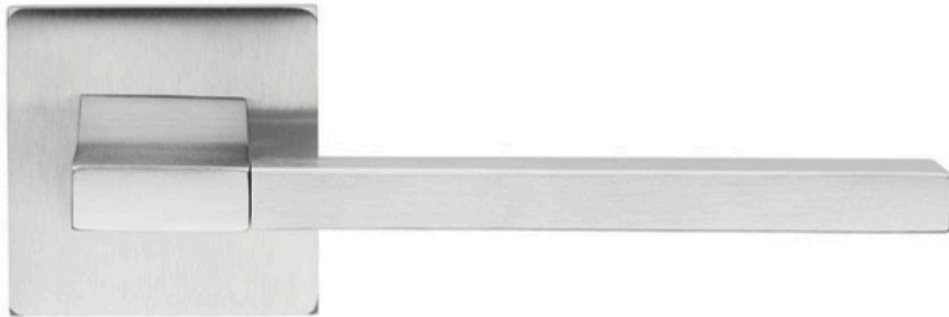

CHANGE B 02

design:
Sandro Santantonio
made in italy

Ottone
Brass

MS CB14



OCS
Cromo satinato
Satin chrome



CCS
Cromo - Cromo satinato
Chrome - Satin chrome



OBN
Bianco
White



ONO
Nero
Black

R CB25
martellina DK
DK window handle



CLOE



CLOE

design:
Dnd technical division
made in italy

Ottone
Brass

CL40



PVD-BG | forte®
Oro antico lucido
Antique bright gold



PVD-SG | forte®
Oro antico satinato
Antique satin gold



PGS | forte®
Grafite satinato
Satin graphite



OC
Cromo lucido
Polished chrome



OCS
Cromo satinato
Satin chrome



ONO
Nero
Black

CL22V
martellina DK
DK window handle



CL27
maniglia
e pull
handle



CLOE 02



CLOE 02

design:
Dnd technical division
made in italy

Ottone
Brass

FINE CL41



PVD-BG | forte®
Oro antico lucido
Antique bright gold



PVD-SG | forte®
Oro antico satinato
Antique satin gold



PGS | forte®
Grafite satinato
Satin graphite



OC
Cromo lucido
Polished chrome



OCS
Cromo satinato
Satin chrome



ONO
Nero
Black

R CL25
martellina DK
DK window handle



PROJECT



PROJECT

design:
Dnd technical division
made in italy

Ottone
Brass

VIS PR12



OS
Satinato
Satin



AB
Bronzato
Antique bronze



OCS
Cromo satinato
Satin chrome



ONS
Nickel satinato
Satin nickel

U



ONO
Nero
Black

VIS PR22V
martellina DK
DK window handle



U PR22U
martellina DK Unico
Unico DK window handle



PR27
maniglia
e pull
handle



PR29
maniglia
e pull
handle



PROJECT 02



PROJECT 02

design:
Dnd technical division
made in italy

Ottone
Brass

vis PR14



OS
Satinato
Satin



AB
Bronzato
Antique bronze



OCS
Cromo satinato
Satin chrome



ONS
Nickel satinato
Satin nickel



ONO
Nero
Black

vis PR25V
martellina DK
DK window handle



PR36
pomolo
knob



PR27
maniglia
e pull
handle



PR29
maniglia
e pull
handle



HAVANA



HAVANA

design:
Studio Hot Lab
made in italy

Ottone e pelle di prima
qualità "pieno fiore"
Brass and high quality
leather

FINE HV40



PVD-BG | forte® + VE
Oro antico lucido + Verde
Antique bright gold + Green



PVD-SG | forte® + VE
Oro antico satinato + Verde
Antique satin gold + Green



PVD-BG | forte® + PA
Oro antico lucido + Papaya
Antique bright gold + Papaya



PVD-SG | forte® + PA
Oro antico satinato + Papaya
Antique satin gold + Papaya



OC + NA
Cromo lucido + Navy
Polished chrome + Navy



OCS + NA
Cromo satinato + Navy
Satin chrome + Navy



OCS + PA
Cromo satinato + Papaya
Satin chrome + Papaya

VIS HV22V
martellina DK
DK window handle



DOLCE



DOLCE

design:
Mauro Ronchi
made in italy

Ottone
Brass

DO40



PVD-SG | forte®
Oro antico satinato
Antique satin gold



OGH
Bronzo satinato opaco
Matt satin bronze



OCS
Cromo satinato
Satin chrome



ONS
Nickel satinato
Satin nickel

DO22V
martellina DK
DK window handle



DO10
maniglia su placca
handle on plate



LINEAR



LINEAR

design:
Mauro Ronchi
made in italy

Ottone
Brass

LI40



PVD-BG | forte®
Oro antico lucido
Antique bright gold



PVD-SG | forte®
Oro antico satinato
Antique satin gold



OGH
Bronzo satinato opaco
Matt satin bronze



OC
Cromo lucido
Polished chrome

U



OCS
Cromo satinato
Satin chrome

LI22V
martellina DK
DK window handle



LI22U
martellina DK Unico
Unico DK window handle



LI10
maniglia su placca
handle on plate



ART



ART

design:
Mauro Ronchi
made in italy

Ottone
Brass

FINE AR40



PVD-SG | forte®
Oro antico satinato
Antique satin gold



PVD-SB | forte®
Bronzo satinato
Satin bronze



OC
Cromo lucido
Polished chrome



OCS
Cromo satinato
Satin chrome

U



ONS
Nickel satinato
Satin nickel

VIS AR22V
martellina DK
DK window handle



U AR22U
martellina DK Unico
Unico DK window handle



AR10
maniglia su placca
handle on plate



BLIP

ON DEMAND



BLIP

design:
Karim Rashid
made in italy

Ottone
Brass

VIS **BL12**



OCS
Cromo satinato
Satin chrome



ONO
Nero
Black

VITA

ON DEMAND



VITA

design:
Mauro Ronchi
made in italy

Ottone
Brass

VIS **VI12**



PVD-BG | forte®
Oro antico lucido
Antique bright gold



PGS | forte®
Grafite satinato
Satin graphite



OC
Cromo lucido
Polished chrome



OCS
Cromo satinato
Satin chrome



ONS
Nickel satinato
Satin nickel

VIS **VI22V**
martellina DK
DK window handle



VI10
maniglia su placca
handle on plate



OVUM



OVUM

design:
Poggi Mariani
made in italy

Ottone
Brass

FINE 62/40



OLV
Lucido
Polished



BSO
Bronzo sabbiato opaco
Matt sandblasted bronze



OCS
Cromo satinato
Satin chrome



OBN
Bianco
White



ONO
Nero
Black

VIS 62V
martellina DK
DK window handle



TWIST

design:
Karim Rashid
made in italy

Ottone
Brass

ON DEMAND



R TW14



OC
Cromo lucido
Polished chrome



OCS
Cromo satinato
Satin chrome



ONS
Nickel satinato
Satin nickel

VIS TW22V
martellina DK
DK window handle



TWIST 02

design:
Karim Rashid
made in italy

Ottone
Brass

ON DEMAND



VS TW13



OC
Cromo lucido
Polished chrome



OCS
Cromo satinato
Satin chrome



ONS
Nickel satinato
Satin nickel

R TW25
martellina DK
DK window handle



PROJECT ZANCATA

design:
Dnd technical division
made in italy

Ottone
Brass



vis P012



OC
Cromo lucido
Polished chrome



OCS
Cromo satinato
Satin chrome



ONO
Nero
Black

PROJECT ZANCATA 02

design:
Dnd technical division
made in italy

Ottone
Brass



VS P014



OC
Cromo lucido
Polished chrome



OCS
Cromo satinato
Satin chrome



ONO
Nero
Black

SILVYANA

design:
Poggi Mariani
made in italy

Ottone
Brass

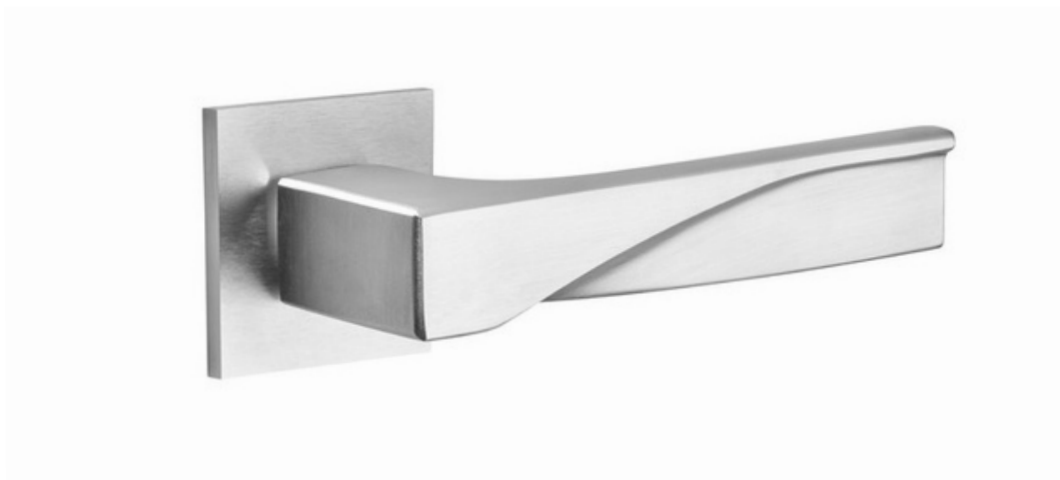

FR 52/41



OCS
Cromo satinato
Satin chrome



ONO
Nero
Black

VIS 52QV
martellina DK
DK window handle



THELMA

design:
Poggi Mariani
made in italy

Ottone
Brass



vis 82 /12



OLV
Lucido
Polished



OS
Satinato
Satin



OCS
Cromo satinato
Satin chrome



ONO
Nero
Black

vis 82V
martellina DK
DK window handle



ELENA

design:
Poggi Mariani
made in italy

Ottone
Brass



119/40



OLV
Lucido
Polished



OC
Cromo lucido
Polished chrome



OCS
Cromo satinato
Satin chrome



ONO
Nero
Black

119V
martellina DK
DK window handle



MJ

design:
Poggi Mariani
made in italy

Ottone
Brass



85/40



OS
Satinato
Satin



OC
Cromo lucido
Polished chrome



OCS
Cromo satinato
Satin chrome



ONO
Nero
Black

85V
martellina DK
DK window handle



MANIGLIE PREMIUM

PREMIUM DOOR HANDLES

Alessandro Gnocchi



Designer dal 2010, ha intrapreso un percorso professionale caratterizzato da creatività, passione e un costante impegno nella ricerca di soluzioni innovative. Si è formato presso il Politecnico di Milano e ha arricchito il suo bagaglio culturale e accademico con un periodo di studi all'Universidad Complutense de Madrid. Attualmente vive e lavora a Milano, città dinamica e vibrante che rappresenta un punto di riferimento mondiale per il design e la creatività. Qui si dedica alla progettazione di arredi e prodotti di consumo, con un approccio che coniuga estetica e funzionalità, ponendo particolare attenzione alla sostenibilità e all'innovazione nei materiali. Nel corso della sua carriera, ha collaborato con numerosi brand di rilievo, tra cui Belca, Danese Milano, InternoItaliano, Moleskine, Plust e Viceversa, oltre a molti altri.

Designer since 2010, he embarked on a professional path characterized by creativity, passion and a constant commitment to the search for innovative solutions. He trained at the Milan Polytechnic and enriched his cultural and academic background with a period of study at the Universidad Complutense de Madrid. He currently lives and works in Milan, a dynamic and vibrant city that represents a worldwide reference point for design and creativity. Here he focuses on the design of furniture and consumer products, with an approach that combines aesthetics and functionality, paying particular attention to sustainability and innovation in materials. Over the course of his career, he has collaborated with a number of prominent brands, including Belca, Danese Milano, InternoItaliano, Moleskine, Plust and Viceversa, among many others.

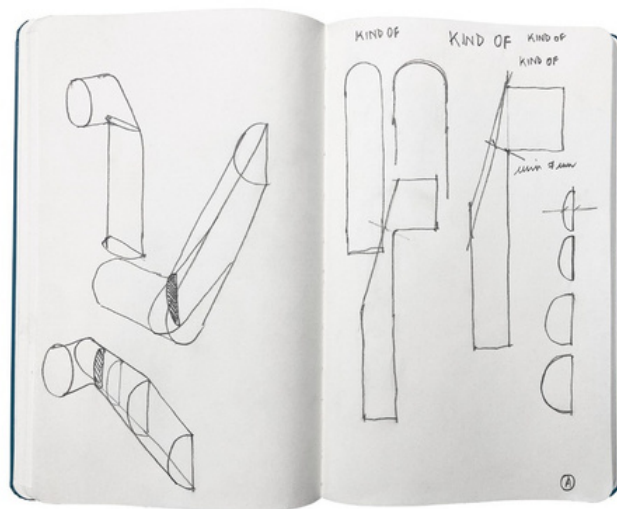

Kind of
Disegni della maniglia di /
Handle sketches by
Alessandro Gnocchi

KIND OF NEW



Il design prende vita da una forma inizialmente semplice, essenziale ed elegante, che si trasforma attraverso un attento processo di sottrazione. La riduzione mirata del materiale nella zona della piega non solo conferisce leggerezza visiva, ma migliora anche l'ergonomia della presa, garantendo un comfort superiore.

The design comes to life from an initially simple, essential, and elegant shape, which transforms through a careful subtraction process. The targeted reduction of material in the bending area not only provides visual lightness but also enhances the grip's ergonomics, ensuring superior comfort.

KIND OF NEW



KIND OF

design:
Alessandro Gnocchi
made in italy

Zama
Zamak

VIS **KN12**



ZRO
Oro satinato
Satin gold



ZBR
Bronzo
Bronze



ZCS
Cromo satinato
Satin chrome



ZBN
Bianco
White



ZAN
Antracite
Anthracite



ZNE
Nero
Black

VIS **KN22V**
martellina DK
DK window handle



SPOT NEW

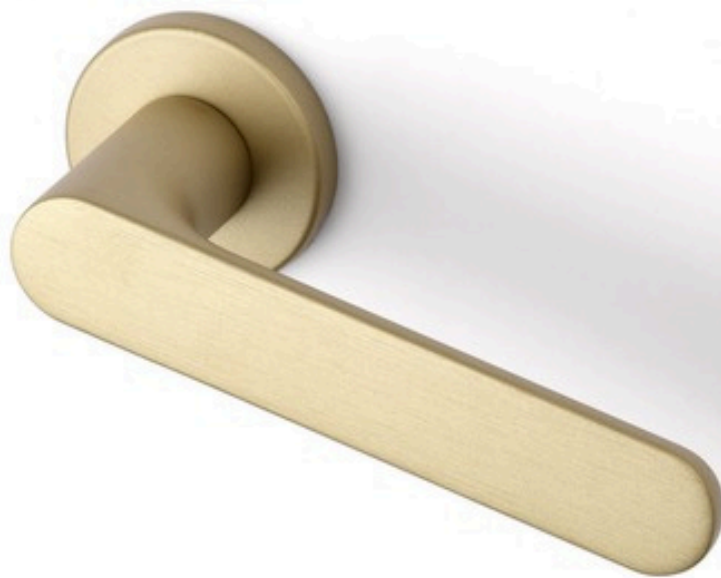

SPOT

design:
Dnd technical division
made in italy

Zama
Zamak

VIS S012



ZRO
Oro satinato
Satin gold



ZBR
Bronzo
Bronze



ZCS
Cromo satinato
Satin chrome



ZBN
Bianco
White



ZAN
Antracite
Anthracite



ZNE
Nero
Black

VIS S022V
martellina DK
DK window handle



U S022U
martellina DK Unico
Unico DK window handle



PLURIS



Una maniglia dal design nitido, pulito ed essenziale trova la forma di un volume rettangolare stondato. La rosetta è contenuta nella proiezione della leva.

A handle with a sharp, clean and essential design finds its shape in a rounded rectangular volume. The escutcheon is contained within the projection of the lever.

PLURIS

design:
Giulio Iacchetti
made in italy

Zama
Zamak

PS48



ZRO
Oro satinato
Satin gold



ZBR
Bronzo
Bronze



ZCS
Cromo satinato
Satin chrome



ZBN
Bianco
White



ZAN
Antracite
Anthracite



ZNE
Nero
Black

Philippe Tabet



Nato e cresciuto in Francia, a Versailles, ha studiato design industriale a Lione e Parigi. Vive a Milano, dove dal 2014 ha sede il suo studio di progettazione e dove insegna presso Domus Academy e Naba. Collabora con aziende rinomate quali Pianca, Lexon, Infiniti Design e Plust e al contempo sviluppa un suo percorso artigianale, con processi e risultati che esplorano materiali e tecniche di lavorazione – come per la serie di maschere Order. Ha vinto il premio Infiniti Design nel 2014 e Young&Design nel 2017; ha ottenuto il Good Design Award nel 2018.

Born and raised in Versailles, France, he studied industrial design in Lyon and Paris. He now lives in Milan, where he established his design firm in 2014 and where he teaches at Domus Academy and Naba. He collaborates with renowned companies such as Pianca, Lexon, Infiniti Design and Plust, whilst at the same time following his own path as a craftsman, with processes and results that are explorations of materials and techniques, as can be seen from Order, his series of masks. He won the Infiniti Design award in 2014 and the Young&Design award in 2017, before garnering the Good Design Award in 2018.

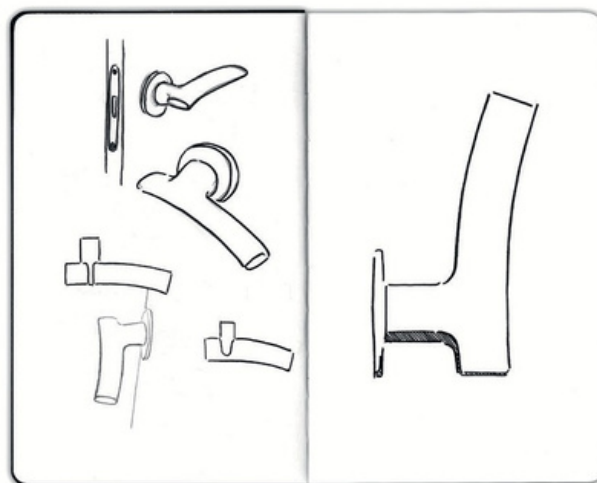

San
Disegni della maniglia di /
Handle sketches by
Philippe Tabet

SAN



Come a ricordare l'elegante e slanciato profilo di una katana. Curve morbide e in tangenza caratterizzano questa originale maniglia dall'estetica e dal nome, di ispirazione giapponese.

Delicately reminiscent of the elegant, slender profile of a katana. Soft, tangential curves characterise this original handle with a Japanese-inspired name and aesthetic.

SAN

design:
Philippe Tabet
made in italy

Zama
Zamak

vis SN12



ZRO
Oro satinato
Satin gold



ZBR
Bronzo
Bronze



ZCS
Cromo satinato
Satin chrome



ZAN
Antracite
Anthracite

U



ZNE
Nero
Black

vis SN22V
martellina DK
DK window handle



U SN22U
martellina DK Unico
Unico DK window handle



SAN 02

design:
Philippe Tabet
made in italy

Zama
Zamak

VIS SN14



ZRO
Oro satinato
Satin gold



ZBR
Bronzo
Bronze



ZCS
Cromo satinato
Satin chrome



ZAN
Antracite
Anthracite



ZNE
Nero
Black

VIS SN25V
martellina DK
DK window handle



Mario Scairato



Nato a Paestum nel 1989, vive e lavora a Milano dove si occupa di furniture e product design e direzione artistica. Nel suo lavoro ricerca e indaga le forme espressive del design con un approccio innovativo e contemporaneo. I suoi progetti sono stati esposti presso Triennale di Milano, ADI Design Museum, Rossana Orlandi Gallery, Casa do Design Matosinhos, Design Museum Holon. Ha disegnato prodotti per diverse aziende italiane, tra cui Abet Laminati, Alessi, Bulgari, Dnd, Internoitaliano, Lispi, Moleskine.

Born in Paestum in 1989, he lives and works in Milan, where he focuses on furniture and product design as well as art direction. He researches and explores the expressive forms of design with an innovative and contemporary approach. His projects have been exhibited at the Triennale di Milano, the ADI Design Museum, Rossana Orlandi Gallery, Casa do Design Matosinhos, and the Design Museum Holon. He has designed products for various Italian companies, including Abet Laminati, Alessi, Bulgari, Dnd, Internoitaliano, Lispi, and Moleskine.

Alessandro Stabile



Alessandro Stabile è un designer industriale focalizzato sulla ricerca di nuovi punti di equilibrio tra innovazione tecnica, tipologica e formale. Nel campo della tecnologia, indirizza la spinta all'innovazione verso le consuetudini del presente, semplificando l'interazione e lavorando su ciò che le forme comunicano. Nel corso della sua carriera ha lavorato per brand come Magis, Alessi, Moleskine, De'Longhi, ricevendo numerosi riconoscimenti, tra cui la Menzione d'Onore al Compasso d'Oro, l'Archiproducts, il Red Dot e l'IF Design Award.

Alessandro Stabile is an industrial designer focused on exploring new points of balance between technical, typological, and formal innovation. In the field of technology, Stabile directs the drive for innovation towards present customs, simplifying interaction and working on what shapes communicate. Throughout his career, Stabile has worked with clients such as Magis, Alessi, Moleskine, and De'Longhi, and receiving numerous awards including the Honorable Mention at the Compasso d'Oro, Archiproducts, Red Dot, and IF Design Award.

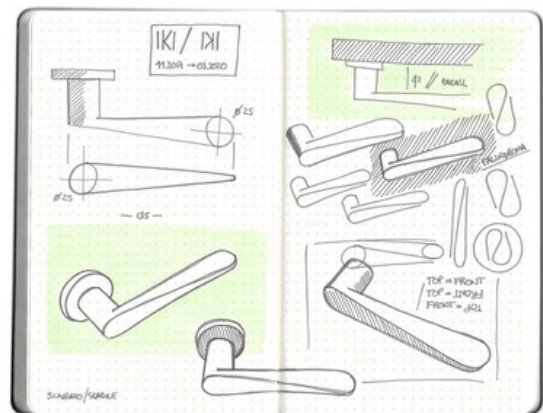

Iki
Disegni della maniglia di /
Handle sketches by
Mario Scairato +
Alessandro Stabile

IKI



Una costruzione formale palindroma: il profilo della vista superiore è identico a quello della vista frontale, ribaltato di 180 gradi. Una forma elegante ed essenziale, un volume mutevole che suggerisce all'utente la presa con il suo profilo frontale.

A palindromic structural form: the profile in the view from above is identical to that of the frontal view, but reversed by 180 degrees. An elegant and essential form, a mutable volume that suggests the proper grip with its frontal profile.

IKI



IKI

design:
Mario Sciarato
Alessandro Stabile

Zama
Zamak

made in italy

VIS IK12



ZRO
Oro satinato
Satin gold



ZBR
Bronzo
Bronze



ZCS
Cromo satinato
Satin chrome



ZAN
Antracite
Anthracite

U



ZNE
Nero
Black

VIS IK22V
martellina DK
DK window handle



U IK22U
martellina DK Unico
Unico DK window handle



LUCE



La maniglia come fatto scultoreo, dove la luce evidenzia morbidezze e taglia i volumi in modo netto per restituirci l'idea stessa di un concetto plastico fuori dal tempo.

The handle as sculpture, where light brings out softness and volumes with clarity, conveying the idea of a timelessly shaped object.

LUCE

design:
Dnd technical division
made in italy

Zama
Zamak

VIS LC12



ZRO
Oro satinato
Satin gold



ZBR
Bronzo
Bronze



ZOR
Oro lucido
Bright polished



ZC
Cromo lucido
Polished chrome



ZCS
Cromo satinato
Satin chrome



ZNS
Nickel satinato
Satin nickel



ZBN
Bianco
White



ZAN
Antracite
Anthracite

U



ZNE
Nero
Black

VIS LC30V
martellina DK
DK window handle



U LC30U
martellina DK Unico
Unico DK window handle



LC50
maniglione per alzante
scorrevole
pull handle for lift sliding
system



LC26
maniglione
e pull
handle



LUCE 02

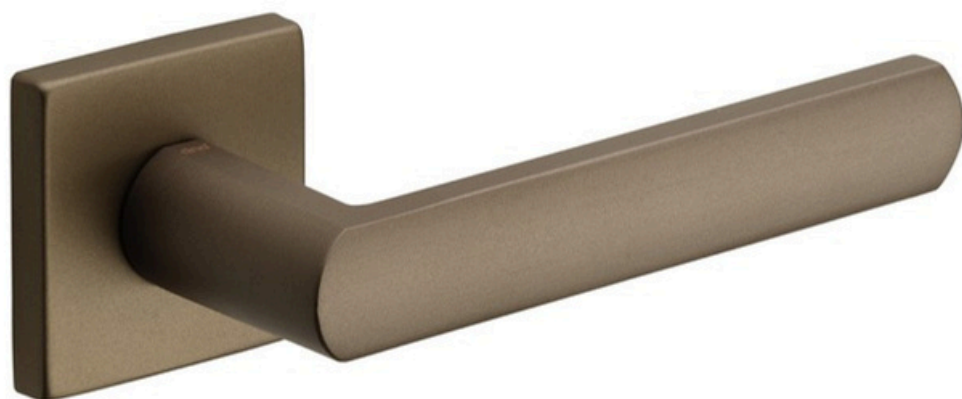

LUCE 02

design:
Dnd technical division
made in italy

Zama
Zamak

VIS LC14



ZRO
Oro satinato
Satin gold



ZBR
Bronzo
Bronze



ZC
Cromo lucido
Polished chrome



ZCS
Cromo satinato
Satin chrome



ZNS
Nickel satinato
Satin nickel



ZBN
Bianco
White



ZAN
Antracite
Anthracite



ZNE
Nero
Black

VIS LC31V
martellina DK
DK window handle



LC60
maniglione per alzante scorrevole
pull handle for lift sliding system



LUCE P



Una leva dalle geometrie solide e pulite, disegnate e costruite con attenzione intorno a un angolo di 90 gradi. Presa ergonomica e appeal contemporaneo, con la luce che enfatizza i profili.

A lever with solid, clean geometries, carefully designed and constructed around a 90-degree angle. Ergonomic grip and contemporary appeal, with light emphasising the profiles.

LUCE P

design:
Dnd technical division
made in italy

Zama
Zamak

VIS LP12



ZRO
Oro satinato
Satin gold



ZBR
Bronzo
Bronze



ZOR
Oro lucido
Bright polished



ZC
Cromo lucido
Polished chrome



ZCS
Cromo satinato
Satin chrome



ZNS
Nickel satinato
Satin nickel



ZBN
Bianco
White



ZAN
Antracite
Anthracite

U



ZNE
Nero
Black

VIS LP22V
martellina DK
DK window handle



U LP22U
martellina DK Unico
Unico DK window handle



LP50
maniglione per alzante scorrevole
pull handle for lift sliding system

LUCE P 02



LUCE P 02

design:
Dnd technical division
made in italy

Zama
Zamak

VIS LP14



ZRO
Oro satinato
Satin gold



ZBR
Bronzo
Bronze



ZC
Cromo lucido
Polished chrome



ZCS
Cromo satinato
Satin chrome



ZNS
Nickel satinato
Satin nickel



ZBN
Bianco
White



ZAN
Antracite
Anthracite



ZNE
Nero
Black

VIS LP25V
martellina DK
DK window handle



LP60
maniglione per alzante scorrevole
pull handle for lift sliding system



CHOP



CHOP

design:
Didier Schweizer
made in italy

Zama
Zamak

VIS CP12



ZRO
Oro satinato
Satin gold



ZBR
Bronzo
Bronze



ZC
Cromo lucido
Polished chrome



ZCS
Cromo satinato
Satin chrome



ZAN
Antracite
Anthracite



ZNE
Nero
Black

VIS CP22V
martellina DK
DK window handle



U CP22U
martellina DK Unico
Unico DK window handle



ESA



ESA

design:
Mauro Ronchi
made in italy

Alluminio e zama
Aluminium and zamak

VIS ES14



CCS
Cromo - Cromo satinato
Chrome - Satin chrome



CBI
Cromo - Bianco
Chrome - White



SBI
Cromo satinato - Bianco
Satin chrome - White



CNE
Cromo - Nero
Chrome - Black



SNE
Cromo satinato - Nero
Satin chrome - Black



ZNE
Nero
Black

VIS ES25V
martellina DK
DK window handle



SOCHIC



SOCHIC

design:
Dnd technical division
made in italy

Zama
Zamak

VIS SC12



ZCS
Cromo satinato
Satin chrome



ZNE
Nero
Black

SOCHIC 02

VIS SC14



ZCS
Cromo satinato
Satin chrome



ZNE
Nero
Black

VIS SC22V
martellina DK
DK window handle



U SC22U
martellina DK Unico
Unico DK window handle



VIS SC25V
martellina DK
DK window handle



SOCHIC L



SOCHIC L

design:
Dnd technical division
made in italy

Zama + legno
Zamak + wood

VIS SL12



SPB
Cromo satinato + inserto
palissandro bianco
Satin chrome + white Rosewood
insert



SLS
Cromo satinato + inserto larice
sabbia
Satin chrome + sand Larchwood
insert



SRT
Cromo satinato + inserto rovere
tanchè
Satin chrome + tanchè Oakwood
insert



SPL
Cromo satinato + inserto
palissandro scuro
Satin chrome + dark Rosewood
insert

SOCHIC L 02

VIS SL14



NPB
Nero + inserto palissandro bianco
Black + white Rosewood insert



NLS
Nero + inserto larice sabbia
Black + sand Larchwood insert



NRT
Nero + inserto rovere tanchè
Black + tanchè Oakwood insert



NPL
Nero + inserto palissandro
scuro
Black + dark Rosewood insert

VIS SL22V
martellina DK
DK window handle



VIS SL25V
martellina DK
DK window handle



FOLD

design:
Mario Padiglione
made in italy

Zama
Zamak



vis F012



ZRO
Oro satinato
Satin gold



ZBR
Bronzo
Bronze



ZCS
Cromo satinato
Satin chrome



ZAN
Antracite
Anthracite



ZNE
Nero
Black

vis F022V
martellina DK
DK window handle



FOLD 02

design:
Mario Padiglione
made in italy

Zama
Zamak

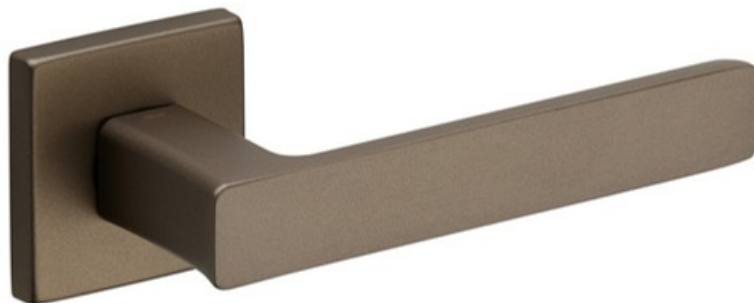

vis F014



ZRO
Oro satinato
Satin gold



ZBR
Bronzo
Bronze



ZCS
Cromo satinato
Satin chrome



ZAN
Antracite
Anthracite



ZNE
Nero
Black

vis F025V
martellina DK
DK window handle



JOY

design:
Nicola Novelletto
made in italy

Zama
Zamak



vis **J012**



ZCS
Cromo satinato
Satin chrome



ZNS
Nickel satinato
Satin nickel



ZAN
Antracite
Anthracite



ZNE
Nero
Black

vis **J022V**
martellina DK
DK window handle



JOY 02

design:
Nicola Novelletto
made in italy

Zama
Zamak



vis J014



ZCS
Cromo satinato
Satin chrome



ZNS
Nickel satinato
Satin nickel



ZAN
Antracite
Anthracite



ZNE
Nero
Black

vis J025V
martellina DK
DK window handle



HOLLY

design:
Dnd technical division
made in italy

Zama
Zamak

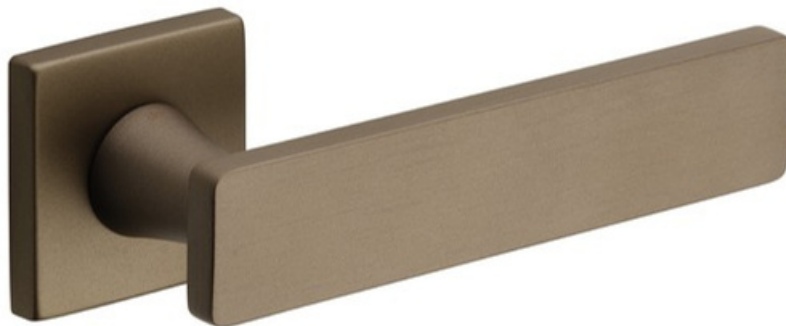

vis H014



ZRO
Oro satinato
Satin gold



ZBR
Bronzo
Bronze



ZCS
Cromo satinato
Satin chrome



ZBN
Bianco
White



ZNE
Nero
Black

vis H025V
martellina DK
DK window handle



MINIMA

design:
Dnd technical division
made in italy

Zama
Zamak



vis **MN12**



ZCCS
Cromo lucido + Cromo satinato
Polished chrome + Satin chrome



ZCBI
Cromo lucido + Bianco
Polished chrome + White



ZCNE
Cromo lucido + Nero
Polished chrome + Black

vis **MN22V**
martellina DK
DK window handle



QUATTRO 02

design:
Dnd technical division
made in italy

Zama
Zamak

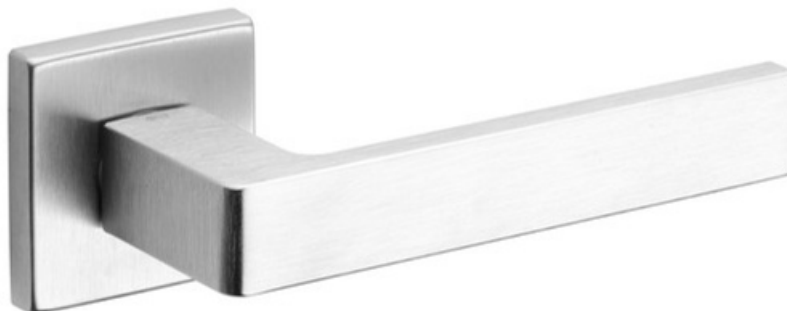

vis 264/14-Z



ZRO
Oro satinato
Satin gold



ZBR
Bronzo
Bronze



ZCS
Cromo satinato
Satin chrome



ZNS
Nickel satinato
Satin nickel



ZBN
Bianco
White



ZAN
Antracite
Anthracite



ZNE
Nero
Black

vis 266-ZV
martellina DK
DK window handle



ELLE

design:
Dnd technical division
made in italy

Zama
Zamak



vis 411/12-Z



ZOR
Oro lucido
Bright polished



ZCS
Cromo satinato
Satin chrome



ZNE
Nero
Black

vis 414-ZV
martellina DK
DK window handle



ARTIK

design:
Dnd technical division
made in italy

Zama
Zamak



vis 893/14



ZCS
Cromo satinato
Satin chrome



ZAN
Antracite
Anthracite



ZNE
Nero
Black

vis 896V
martellina DK
DK window handle



TIPO-Z

design:
Pietro Silva
made in
italy

Zama
Zamak



vis 172 /12-Z



ZRO
Oro satinato
Satin gold



ZBR
Bronzo
Bronze



ZCS
Cromo satinato
Satin chrome



ZNS
Nickel satinato
Satin nickel

vis 177-ZV
martellina DK
DK window handle



S40

made in italy

Acciaio inox AISI 316
Stainless steel AISI 316



vis S40/12



S316
Acciaio AISI 316 satinato
AISI 316 satin steel

S50

made in italy

Acciaio inox AISI 316
Stainless steel AISI 316



vis S50/12



S316
Acciaio AISI 316 satinato
AISI 316 satin steel

S60

made in italy

Acciaio inox AISI 316
Stainless steel AISI 316



vis S60/12



PVD-SG | forte®
Oro antico satinato
Antique satin gold



PVD-SB | forte®
Bronzo satinato
Satin bronze



PGS | forte®
Grafite satinato
Satin graphite



S316
Acciaio AISI 316 satinato
AISI 316 satin steel



S316/N
Nero
Black

MANIGLIE CLASSIC

CLASSIC DOOR HANDLES

ANGELA

design:
Poggi Mariani
made in italy

Ottone
Brass



R 80



OLV
Lucido
Polished



BSO
Bronzo sabbiato opaco
Matt sandblasted bronze



AB
Bronzato
Antique bronze

vis 80V
martellina DK
DK window handle



SIMONA

design:
Poggi Mariani
made in italy

Ottone
Brass



vis 58/12



OLV
Lucido
Polished



BSO
Bronzo sabbiato opaco
Matt sandblasted bronze

vis 58V
martellina DK
DK window handle



BARBARA

design:
Poggi Mariani
made in italy

Ottone
Brass



vis 200/12



OLV
Lucido
Polished



BSO
Bronzo sabbato opaco
Matt sandblasted bronze

vis 200V
martellina DK
DK window handle



AURORA

design:
Poggi Mariani
made in italy

Ottone
Brass



vis 79/12



OLV
Lucido
Polished



BSO
Bronzo sabbato opaco
Matt sandblasted bronze

vis 79V
martellina DK
DK window handle



CLASSIC

design:
Dnd technical division
made in italy

Ottone
Brass



vis 571/12



OLV
Lucido
Polished



OS
Satinato
Satin



OGH
Bronzo satinato opaco
Matt satin bronze



AB
Bronzato
Antique bronze

vis 574V
martellina DK
DK window handle



570
maniglia su placca
handle on plate



FEDORA

design:
Dnd technical division
made in italy

Ottone
Brass



vis 530/12



PVD-BG | forte®
Oro antico lucido
Antique bright gold



PVD-SG | forte®
Oro antico satinato
Antique satin gold



OGH
Bronzo satinato opaco
Matt satin bronze



AB
Bronzato
Antique bronze

vis 529V
martellina DK
DK window handle



LATINA

design:
Mauro Ronchi
made in italy

Ottone
Brass

ON DEMAND



vis 823/12



OLV
Lucido
Polished

vis 829V
martellina DK
DK window handle



820
maniglia su placca
handle on plate



1110
maniglia
e pull
handle



APPIA

design:
Mauro Ronchi
made in italy

Ottone
Brass

ON DEMAND



vis 833/12



OLV
Lucido
Polished



BSO
Bronzo sabbato opaco
Matt sandblasted bronze

vis 839V
martellina DK
DK window handle



830
maniglia su placca
handle on plate



FIORE

design:
Dnd technical division
made in italy

Ottone
Brass

ON DEMAND



522



OLV
Lucido
Polished



OGH
Bronzo satinato opaco
Matt satin bronze

526V
martellina DK
DK window handle



525
maniglia su placca
handle on plate



FIORENZA

design:
Dnd technical division
made in italy

Ottone
Brass

ON DEMAND



523



OLV
Lucido
Polished



OGH
Bronzo satinato opaco
Matt satin bronze

521V
martellina DK
DK window handle



519
maniglia su placca
handle on plate



AIRONE

Ottone / Brass

design:
Mauro Ronchi
made in italy



OLV

OGH

OS

vis 603/12

BEAUTY

Ottone / Brass

design:
Dnd technical division
made in italy

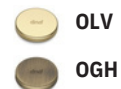

OLV

OGH

B 775/B

BRUXELLES

Ottone / Brass

design:
Dnd technical division
made in italy



 OLV

 OGH

 OCS

 362 /12

DANIELA

Ottone / Brass

design:
Dnd technical division
made in italy



 OLV  ONV

 OGH

 OS

 AB

 OCS

 391/12

GIORGIA

Ottone / Brass

design:
Poggi Mariani
made in italy



vis 22 / 12

LADY

Ottone / Brass

design:
Dnd technical division
made in italy

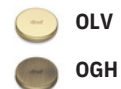

B 568/B

LIRICA

Ottone / Brass

design:
Dnd technical division
made in italy

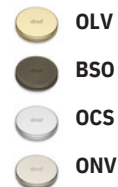

vis 806/12

MARTA

Ottone / Brass

design:
Poggi Mariani
made in italy



vis 300/12

TIFFANY

Ottone / Brass

design:
Poggi Mariani
made in italy



vis 44/12

COMBINAZIONI PARTICOLARI

COMBINATIONS

HOSPITALITY NEW

Maniglie che valorizzano ogni progetto Handles that enhance every project

Dnd propone molteplici servizi per i professionisti che operano nei settori Fit Out e hospitality – mondo contract e dell’ospitalità – per hotel, ristoranti, navi da crociera o uffici, offrendo una selezione di maniglie e accessori di alta qualità, in finiture classiche o di pregio, che rispondono agli alti standard richiesti in questi settori. Soluzioni eleganti, adatte a diversi ambienti e stili, che si adattano a serrature elettroniche e svariati sistemi di chiusura, efficaci e facili da installare, che rispondono a diverse esigenze, sia estetiche che funzionali.

Dnd offers a wide range of services for professionals operating in the Fit Out and hospitality sectors – including contract and hospitality spaces such as hotels, restaurants, cruise ships, or offices – providing a selection of high-quality handles and accessories in classic or premium finishes that meet the high standards required in these industries. Elegant solutions, suitable for various environments and styles, compatible with electronic locks and different locking systems – effective, easy to install, and designed to meet both aesthetic and functional needs.



FIT OUT NEW



Fit Out significa trasformare uno spazio in un'esperienza. Nel mondo dell'interior design contract – che si tratti di hotel, uffici o ristoranti – ogni dettaglio conta. E tra questi, la maniglia non è solo un componente funzionale, ma un segno distintivo, un elemento che completa lo stile e racconta l'identità di un ambiente. Realizzare un fit out completo significa progettare, arredare e rifinire ogni spazio su misura: dalla scelta dei materiali alla selezione di maniglie che dialogano con l'architettura e rispondono alle esigenze di design, ergonomia e durabilità.

Maniglie che valorizzano ogni progetto, garantendo privacy e sicurezza senza sacrificare il design e l'aspetto visivo, per poter offrire ai clienti finali esperienze di pregio in grado di riflettere l'alto livello e l'attenzione al dettaglio del progetto realizzato.

Fit Out means transforming a space into an experience.

In the world of contract interior design – whether for hotels, offices, or restaurants – every detail matters.

Among these, the handle is not just a functional component but a distinctive feature, an element that completes the style and tells the story of a space.

Executing a complete fit out means designing, furnishing, and finishing each area to measure: from material selection to choosing handles that interact with the architecture while meeting design, ergonomic, and durability needs.

Handles that enhance every project, ensuring privacy and security without compromising on design and visual appeal, offering end customers refined experiences that reflect the high level and attention to detail of the completed project.

SERVIZI FIT OUT FIT OUT SERVICES

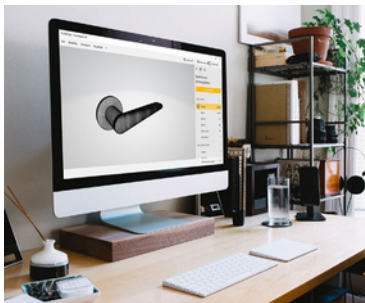

FILE PER PROGETTARE FILES FOR DESIGNING

Dnd mette a disposizione dei progettisti una serie di servizi dedicati, tra cui i file 3D dei prodotti, utilizzabili direttamente nei progetti: entra nel vivo del mondo Dnd, valuta le soluzioni e scegli il miglior design.

Dnd provides designers with a range of dedicated services, including 3D product files that can be used directly within projects: explore the Dnd world, find out different solutions, and choose the design that best fits your needs.



IL CONFIGURATORE THE CONFIGURATOR

Il configuratore Dnd è uno dei tanti strumenti presenti nel *dndmagic*, l'area riservata Dnd. Permette di visualizzare e ambientare tutte le maniglie Dnd – nelle tante finiture disponibili – in spazi connotati da stili diversi.

The Dnd Configurator is one of the many tools available in *dndmagic*, the Dnd reserved area. It allows you to visualize and see Dnd handles – in their many available finishes – within spaces characterized by different interior styles.



SOLUZIONI CUSTOM CUSTOM SOLUTIONS

La personalizzazione diventa parte integrante del progetto: finiture, dimensioni e sistemi possono essere configurati per ottenere prodotti su misura e pensati per rispondere a esigenze progettuali specifiche.

Customisation becomes an integral part of the project: finishes, dimensions and systems can be configured to create bespoke products, carefully crafted to meet specific design requirements.



CAMPIONARIO FINITURE FINISHES SAMPLE BOX

Il campionario finiture Dnd, con pratici dischetti per la creazione di moodboard, supporta i progettisti nella definizione dei concept di interior design. Il box comprende tutte le finiture pregiate, tra cui il rivestimento PVD forte®.

The Dnd finishes sample box, featuring practical discs for moodboard creation, supports designers in defining interior design concepts. The box includes all premium finishes, including the PVD forte® coating.



KIT DI PRESENTAZIONE PRESENTATION KIT

Il kit di presentazione Dnd raccoglie campioni di maniglie, finiture, cataloghi e brochure, offrendo ai progettisti uno strumento completo per valutare e toccare con mano la qualità e il design delle maniglie Dnd.

The Dnd presentation kit brings together handle samples, finishes, catalogues and brochures, offering designers a comprehensive tool to assess and experience firsthand the quality and design of Dnd handles.



PREVENTIVAZIONE QUOTATION

Dnd affianca i professionisti con un servizio di preventivazione dedicato, studiato per accompagnare ogni fase del progetto. Affidabilità degli strumenti, rapidità nelle risposte e un reale supporto alla progettazione.

Dnd offers professionals a dedicated quotation service, designed to support every stage of the project with reliable tools, fast responses and practical assistance for design and planning needs.

COMPACT SYSTEM

NEW

SOLIDITÀ E AFFIDABILITÀ STRONG STRENGTH AND RELIABILITY

Il sistema Ø52 avvitato With the Ø52 threaded system

Il Compact system è una soluzione solida per il fissaggio delle maniglie alle porte. Questo sistema si distingue per l'utilizzo di una rosetta dal Ø52 con filettatura interna, consentendo di avvitare alla sottorosetta permettendo un'integrazione totale tra maniglia e rosetta, unite in un unico blocco solido.

The Compact system is a solid solution for attaching handles to doors. This system is distinguished by a threaded Ø52 rosette, firmly fixed to its sub-rosette, allowing for total integration between the handle and the rosette, joined together in a single solid block.

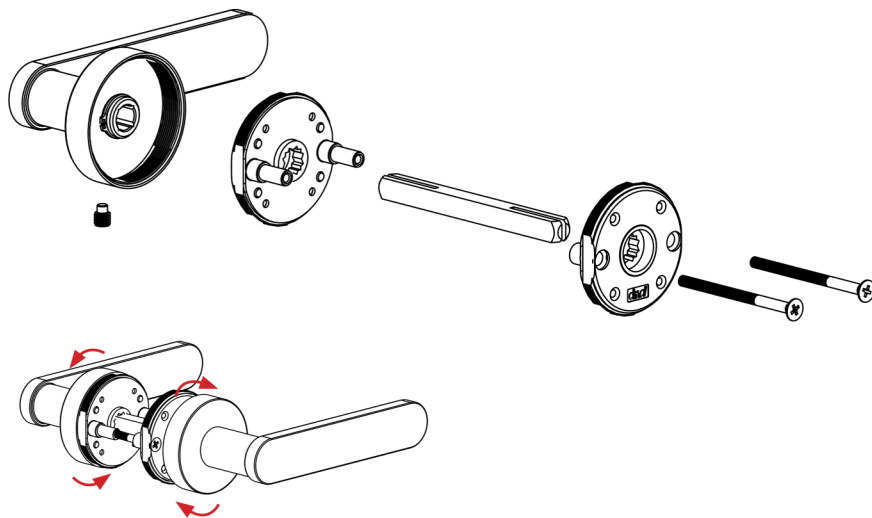

Fissaggio con viti passanti Fixing with through screws

La stabilità della sottorosetta è garantita dalle viti passanti che si ancorano con precisione tramite i fori con interasse 38 mm sulla porta. Questa configurazione non solo migliora la resistenza e la durata, ma semplifica anche il processo di installazione.

The stability of the sub-rosette is ensured by through screws that precisely anchor into the door via the 38 mm centre-to-centre mounting holes. This configuration not only enhances strength and durability but also simplifies the installation process.

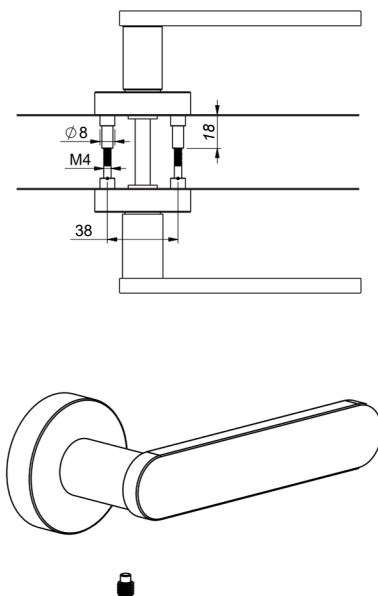

MANIGLIE CON COMPACT SYSTEM

DOOR HANDLES WITH COMPACT SYSTEM

Il sistema Compact è disponibile su richiesta per tutti i modelli di maniglie, previa valutazione dei quantitativi e approvazione da parte dell'azienda.
The Compact system is available upon request for all handle models, subject to evaluation of quantities and approval by the company.

EDRA

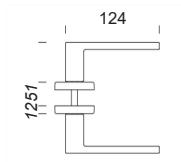
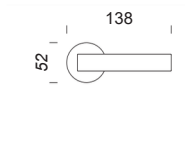
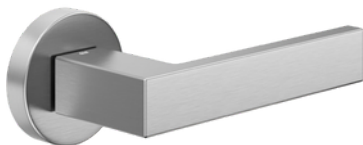

LUXURY

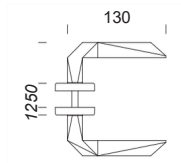
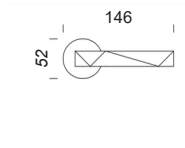
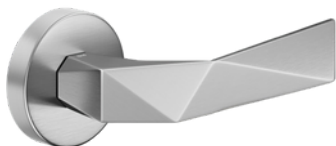

SHORT

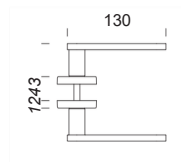
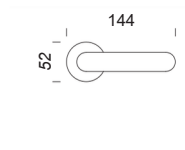
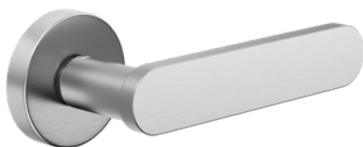

LINEAR

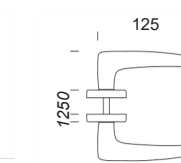
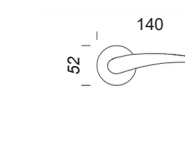

PROJECT

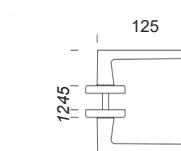
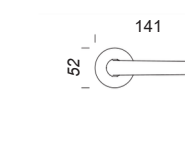

Versioni disponibili

Available versions

senza bocchetta
without escutcheon



con bocchetta patent
with patent escutcheon



con bocchetta yale
with yale escutcheon



con nottolino
with turn & release



KIT HOTEL MANIGLIA / POMOLO HANDLE / KNOB HOTEL KIT

NEW



Compact system per kit hotel maniglia/pomolo Compact system for handle/knob hotel kit

Il Compact system di Dnd è disponibile anche per il kit hotel maniglia/pomolo, offrendo un ancoraggio stabile e sicuro grazie al fissaggio con viti passanti. Questa soluzione garantisce solidità e affidabilità anche in contesti ad alto utilizzo, come le strutture alberghiere, combinando prestazioni tecniche elevate con attenzione al design e all'eleganza degli spazi interni.

The Compact system is also available for the handle/knob hotel kit, providing a stable and secure anchoring thanks to through-screw fastening. This solution ensures strength and reliability even in high-traffic environments, such as hospitality settings, combining high technical performance with careful attention to design and the elegance of interior spaces.

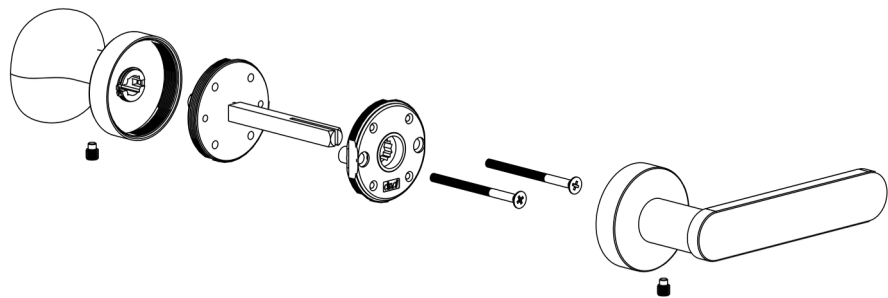
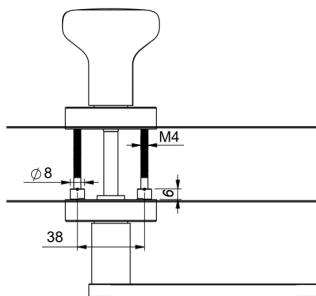

SOLUZIONI PER IL CONTROLLO ACCESSI

SOLUTIONS FOR ACCESS CONTROL

NEW



Massima compatibilità con le serrature elettroniche

Maximum compatibility with electronic locks

Le maniglie Dnd sono compatibili con i sistemi di serrature elettroniche per il controllo accessi, rappresentando una soluzione ideale per progetti di alto profilo a livello internazionale. Le soluzioni Dnd si integrano perfettamente con queste tecnologie, garantendo elevata affidabilità, facilità d'uso e massima compatibilità con i principali brand di "access control" presenti sul mercato.

Dnd handles are compatible with electronic locking systems for access control, representing an ideal solution for high-profile projects worldwide. Dnd solutions integrate seamlessly with these technologies, ensuring high reliability, ease of use, and maximum compatibility with the leading access control brands on the market.

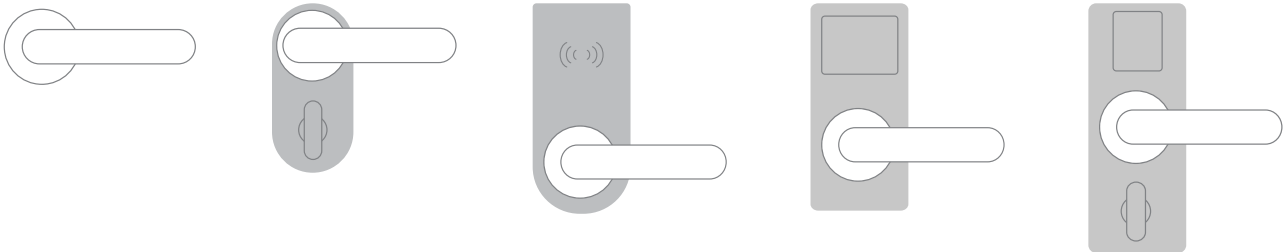

Soluzioni Dnd compatibili con i principali brand di sistemi per il controllo accessi
Dnd solutions compatible with leading access control system brands

COMPONENTI PER PORTE BLINDATE

ACCESSORIES FOR ARMORED DOORS

NEW

Il nuovo programma di componenti per porte blindate Dnd offre ampia libertà progettuale e un perfetto coordinamento estetico con le porte interne.

La gamma, disponibile in versione tonda e quadra, si adatta a diversi stili architettonici e di interior design e consente di coordinare modelli e finiture dei componenti, creando un'armonia cromatica completa con la maniglia scelta.

In questo modo, ogni dettaglio contribuisce a creare un linguaggio stilistico coerente e raffinato.

The new Dnd range of components for security doors offers wide design flexibility and perfect aesthetic coordination with interior doors. The collection, available in both round and square versions, adapts to different architectural and interior design styles and allows the coordination of component models and finishes, creating complete chromatic harmony with the selected handle. In this way, every detail contributes to a coherent and refined design language.



LATO INTERNO

coerenza con le porte interne

Sul lato interno della porta blindata è possibile installare:
- lo stesso modello di maniglia e di finitura

delle porte interne
- la stessa finitura dei componenti, per una perfetta continuità visiva e cromatica tra gli ambienti

Una soluzione ideale per progetti residenziali attenti al design e all'eleganza degli spazi interni.

INTERNAL SIDE

consistency with interior doors

On the internal side of the security door, it is possible to install:

- the same handle model and finish

as the interior doors
- the same component finishes, ensuring perfect visual and chromatic continuity between spaces
An ideal solution for residential projects that focus on design and the elegance of interior spaces.

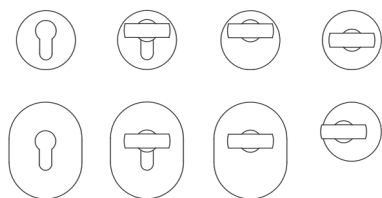

bocchette yale
yale escutcheons

nottolini per foro yale
knobs for yale hole

nottolini per foro decentrato
knobs for off-centre hole

nottolini per limitatore
knobs for limiting device

LATO ESTERNO

libertà progettuale e rispetto del contesto

Sul lato esterno, invece, è possibile scegliere:
- un modello di maniglia differente

o eventualmente un pomolo o un maniglione
- una finitura diversa dei componenti specifica per la porta blindata lato esterno

Il tutto in accordo con le esigenze estetiche dell'architettura esterna dell'abitazione.

EXTERNAL SIDE

design freedom and respect for the context

On the external side of the security door, it is possible to install:

- a different handle model, or alternatively a knob

or a pull handle
- a different component finish specifically designed for the external security door

All in accordance with the aesthetic requirements of the building's external architecture.

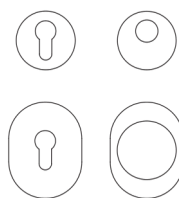

bocchette yale
yale escutcheons

bocchette defender
cover plates for defender

COMPONENTISTICA TONDA PORTA LATO INTERNO

ROUND COMPONENTS INTERNAL SIDE DOOR

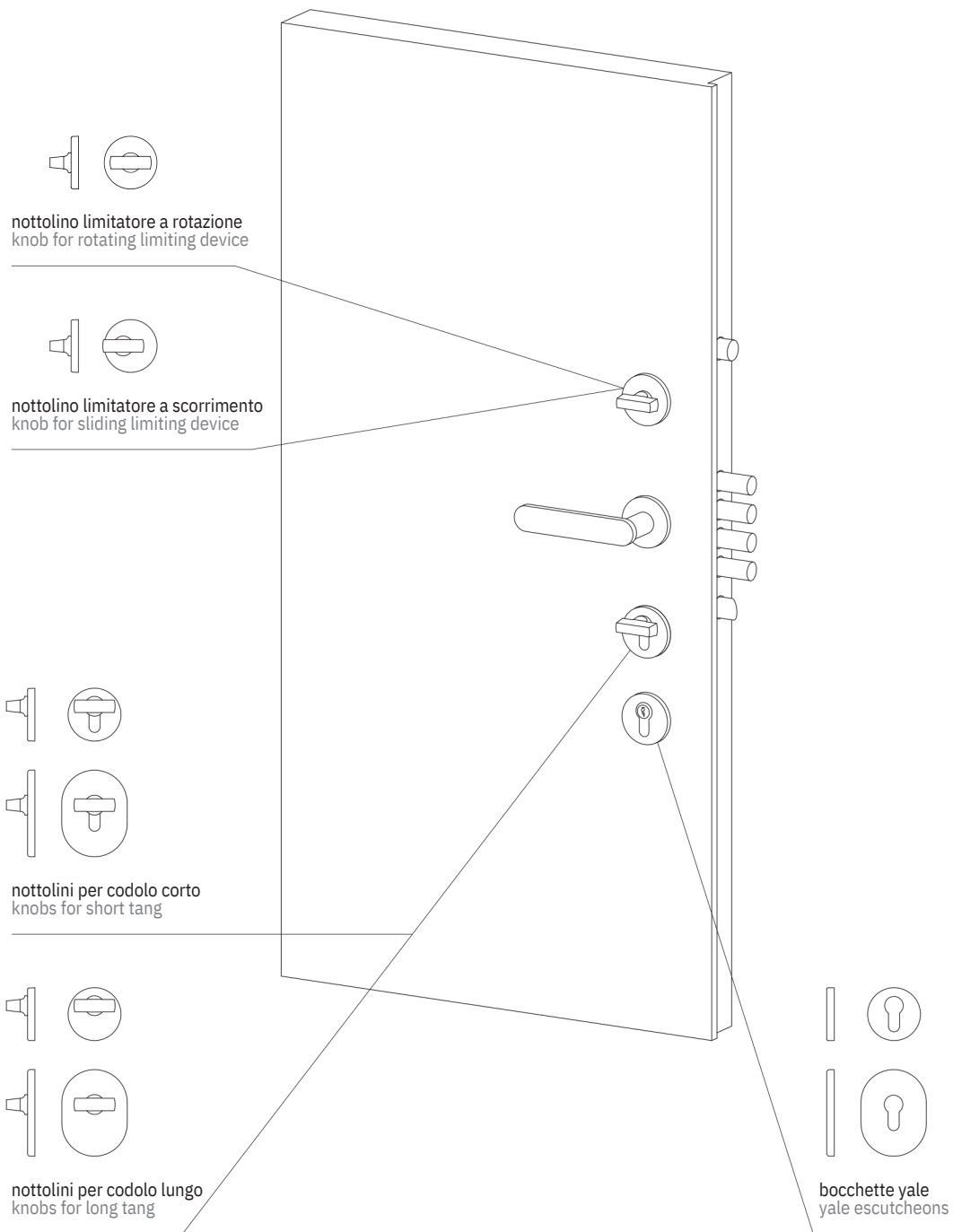

NOTTOLINI PER PORTE BLINDATE

KNOBS FOR ARMORED DOORS

nottolini per limitatore
knobs for limiting device

ottone
brass

EDRA

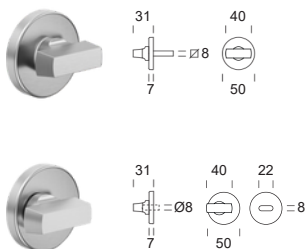

SPOT

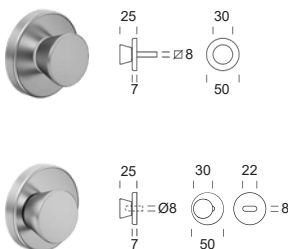

TEDESCO

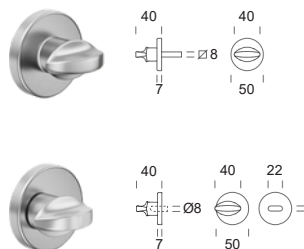

nottolini Ø8
limitatore
a rotazione
Ø8 knobs
for rotating
limiting
device

nottolini Ø8
limitatore
a scorrimento
Ø8 knobs for
sliding
limiting
device

nottolini per foro decentrato
knobs for off-centre hole



EDRA

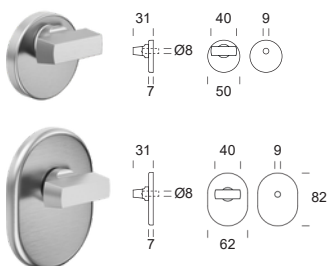

SPOT

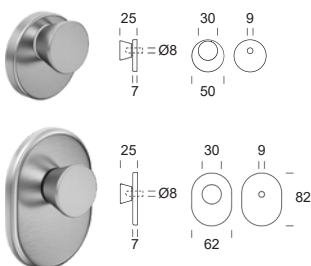

TEDESCO

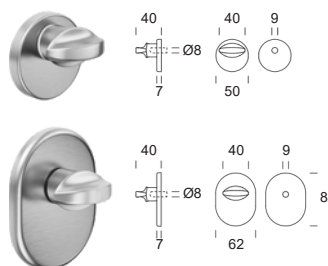

nottolini per
codolo lungo Ø8
Ø8 knobs for
long tang

nottolini per
codolo lungo Ø8
Ø8 knobs for
long tang

nottolini per foro yale
knobs for yale hole



EDRA

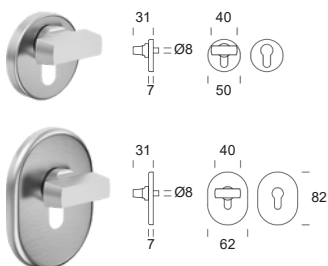

SPOT

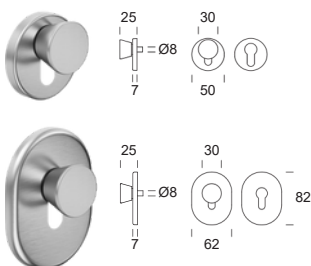

TEDESCO

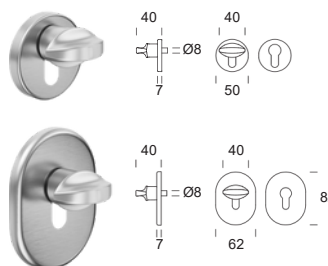

nottolini per
codolo corto Ø8
Ø8 knobs for
short tang

nottolini per
codolo corto Ø8
Ø8 knobs for
short tang



COMPONENTISTICA TONDA PORTA LATO ESTERNO

ROUND COMPONENTS EXTERNAL SIDE DOOR

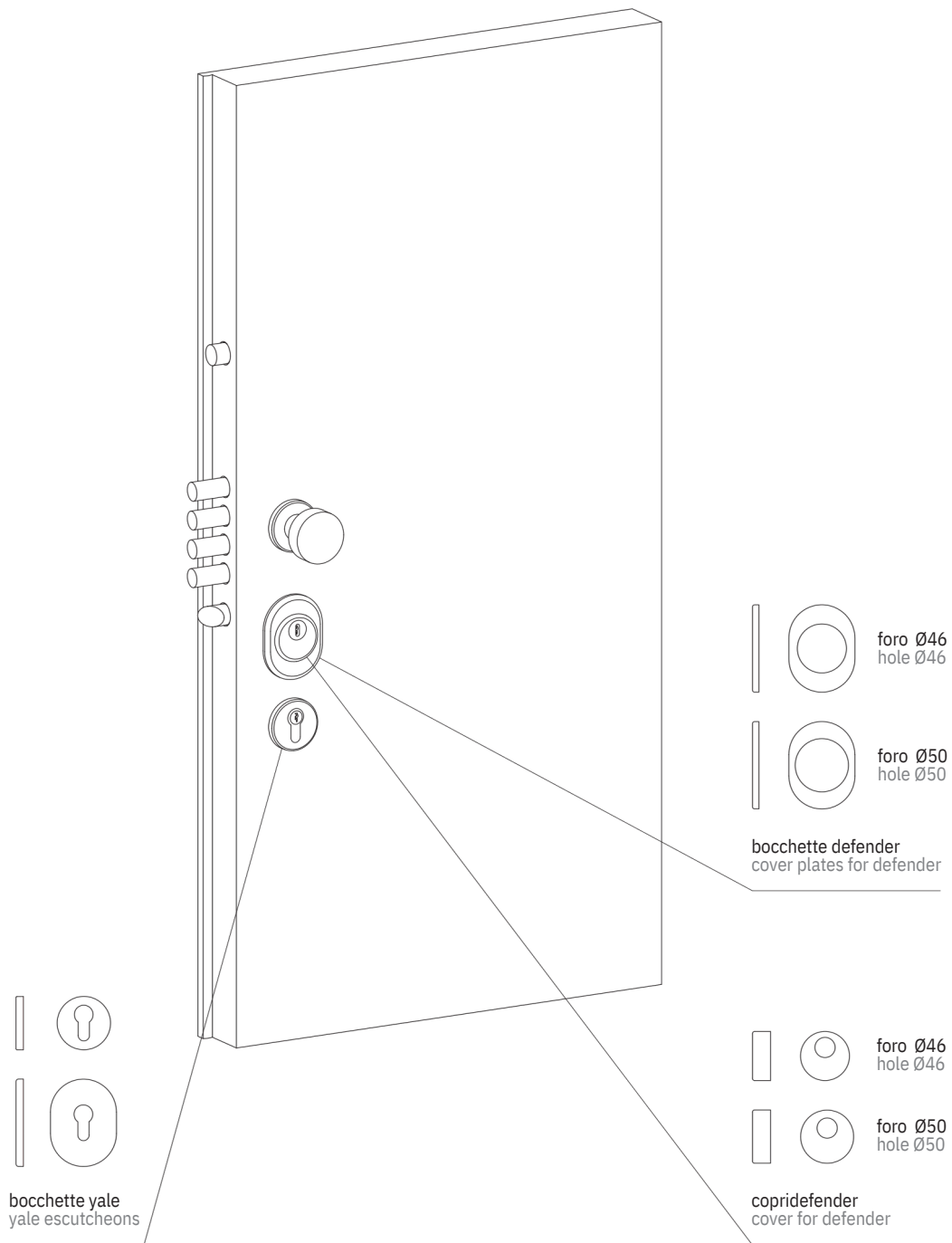

BOCCHETTE DEFENDER

COVER PLATES FOR DEFENDER

ottone
brass

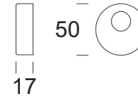
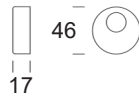
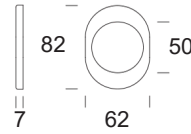
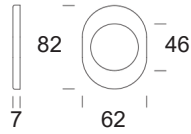

BOCCHETTE YALE

YALE ESCUTCHEONS

ottone
brass

Bocchette Yale per lato interno e lato esterno della porta
Yale escutcheons for the internal and external sides of the door

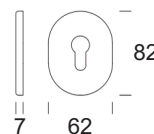

COMPONENTISTICA QUADRA PORTA LATO INTERNO

SQUARE COMPONENTS INTERNAL SIDE DOOR

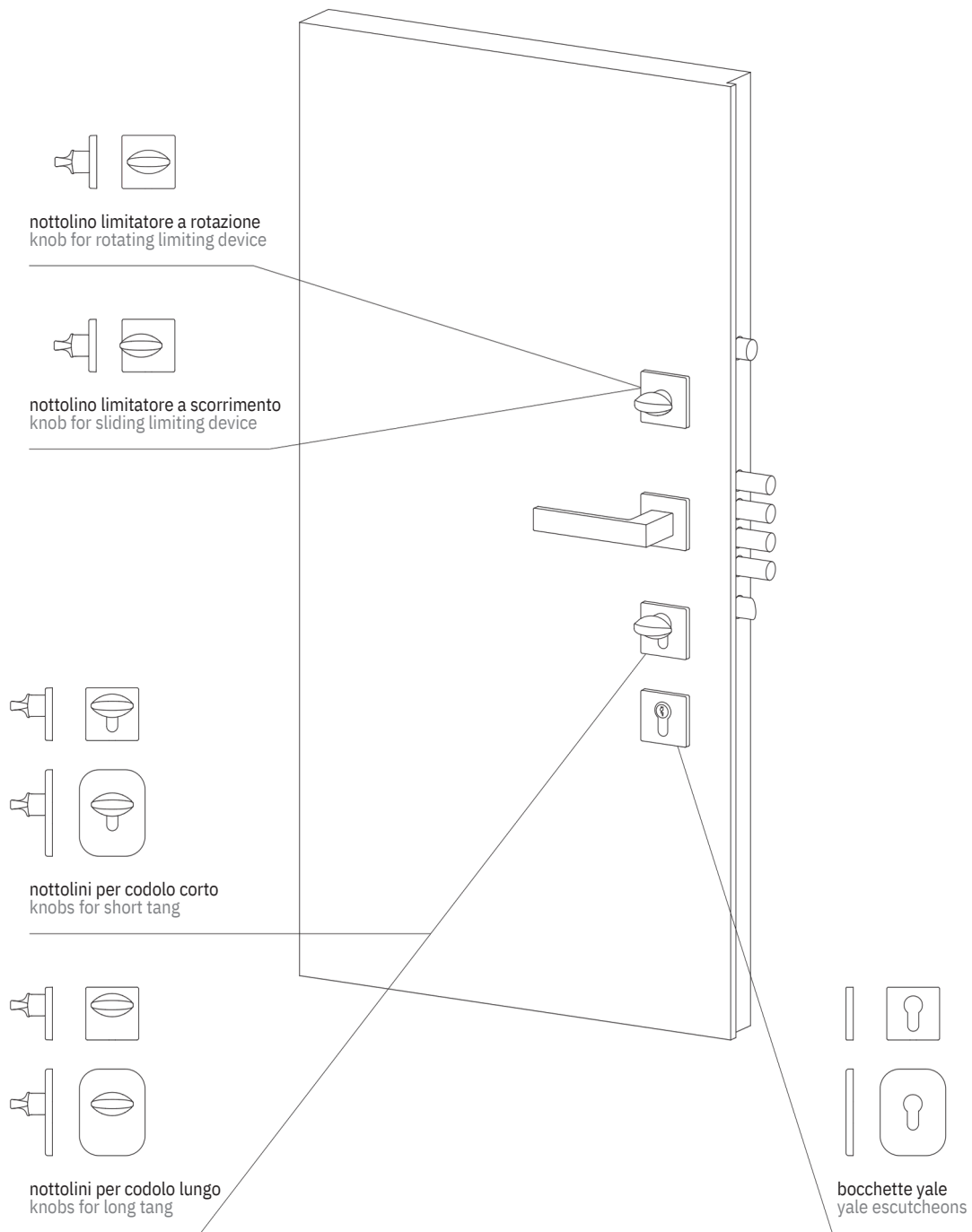

NOTTOLINI PER PORTE BLINDATE

KNOBS FOR ARMORED DOORS

nottolini per limitatore
knobs for limiting device

EDRA

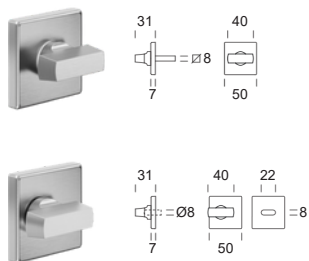

SPOT

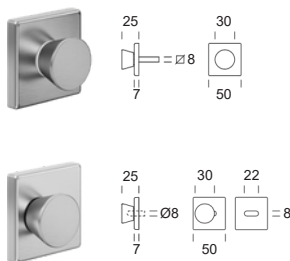

TEDESCO

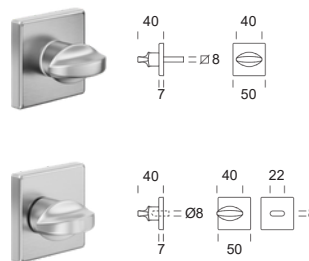

ottone
brass

nottolini $\varnothing 8$
limitatore
a rotazione
 $\varnothing 8$ knobs
for rotating
limiting
device

nottolini $\varnothing 8$
limitatore
a scorrimento
 $\varnothing 8$ knobs for
sliding
limiting
device
ottone
brass

nottolini per foro decentrato
knobs for off-centre hole



EDRA

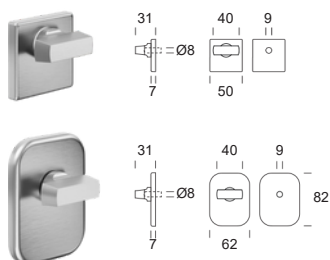

SPOT

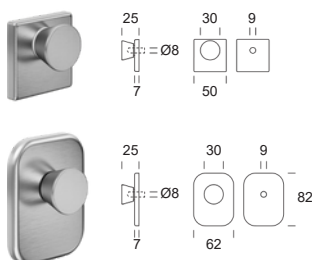

TEDESCO

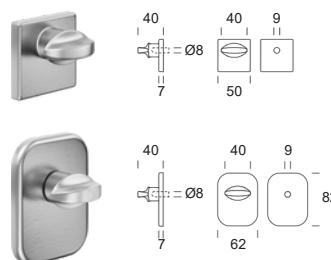

nottolini per
codolo lungo $\varnothing 8$
 $\varnothing 8$ knobs for
long tang

nottolini per
codolo lungo $\varnothing 8$
 $\varnothing 8$ knobs for
long tang

nottolini per foro yale
knobs for yale hole



EDRA

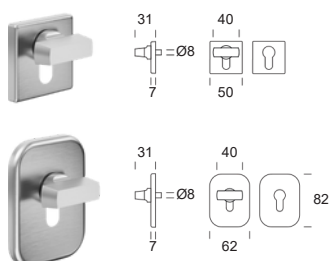

SPOT

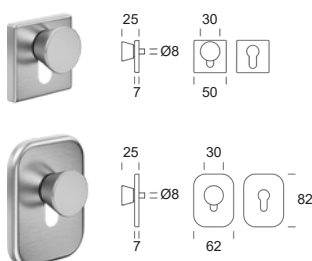

TEDESCO

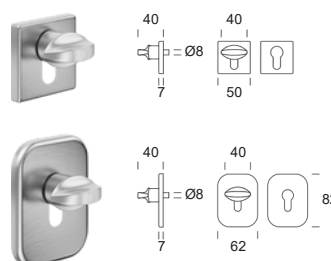

ottone
brass

nottolini per
codolo corto $\varnothing 8$
 $\varnothing 8$ knobs for
short tang

nottolini per
codolo corto $\varnothing 8$
 $\varnothing 8$ knobs for
short tang



COMPONENTISTICA QUADRA PORTA LATO ESTERNO

SQUARE COMPONENTS EXTERNAL SIDE DOOR

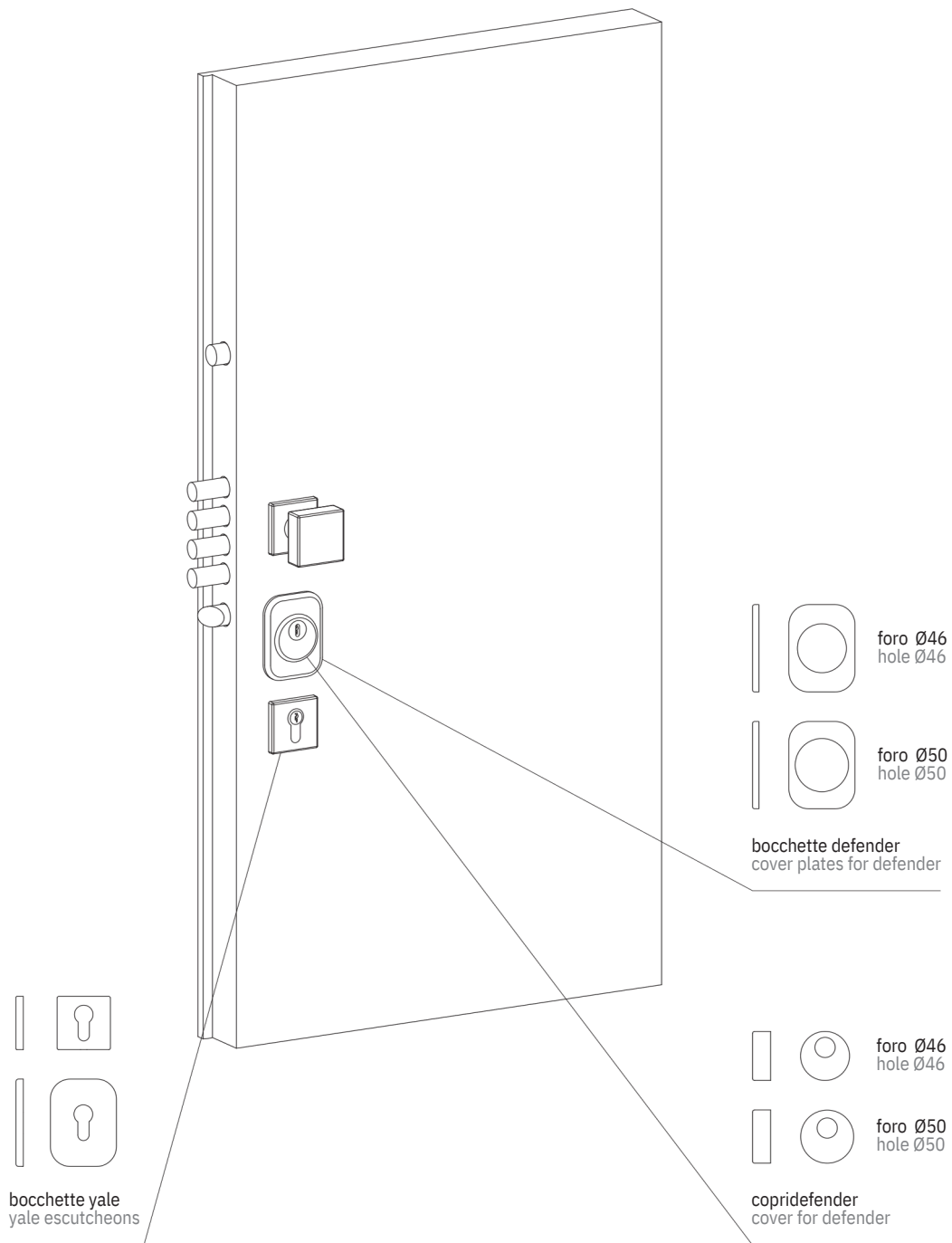

BOCCHETTE DEFENDER

COVER PLATES FOR DEFENDER

ottone
brass

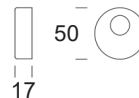
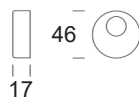
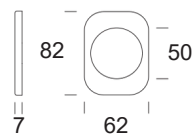
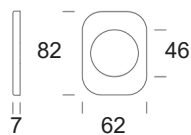

BOCCHETTE YALE

YALE ESCUTCHEONS

ottone
brass

Bocchette Yale per lato interno e lato esterno della porta
Yale escutcheons for the internal and external sides of the door

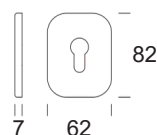

MANIGLIONI

PULL HANDLES

PENCIL NEW

design:
BIG - Bjarke Ingels Group
made in italy

Alluminio
Aluminium



ANT | eco-friendly
Alluminio naturale
Natural aluminium



ARO
Oro satinato
Satin gold



ABR
Bronzo
Bronze



ASV
Silver
Silver



ABN
Bianco
White



ANE
Nero
Black

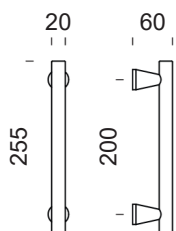

PE27 - singolo
PE28 - set

POD

design:
Holscher Design

Ottone
Brass

made in italy



PVD-BG | forte®
Oroantico lucido
Antique brightgold



PVD-SG | forte®
Oro antico satinato
Antique satin gold



PGS | forte®
Grafite satinato
Satin graphite



OC
Cromo lucido
Polished chrome



OCS
Cromo satinato
Satin chrome



ONO
Nero
Black

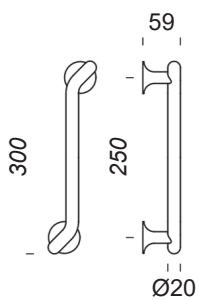

PD27 - singolo
PD28 - set



(IN)FINITO

design:
Alfonso Femia
made in italy

Ottone
Brass



PVD-SB|forte®
Bronzo satinato
Satin bronze



PGS | forte®
Grafite satinato
Satin graphite



OLV
Lucido
Polished



AB
Bronzato
Antique bronze



OC
Cromo lucido
Polished chrome



OCS
Cromo satinato
Satin chrome



ONO
Nero
Black

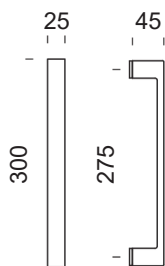

IF27 - singolo
IF28 - set

(IN)FINITO

design:
Alfonso Femia
made in italy

Ottone
Brass



PVD-SB|forte® *
Bronzo satinato
Satin bronze



PGS | forte® *
Grafite satinato
Satin graphite



OLV
Lucido
Polished



AB
Bronzato
Antique bronze



OC
Cromo lucido
Polished chrome



OCS
Cromo satinato
Satin chrome



ONO
Nero
Black

*finiture disponibili solo su placca corta
finishes available only on short plate

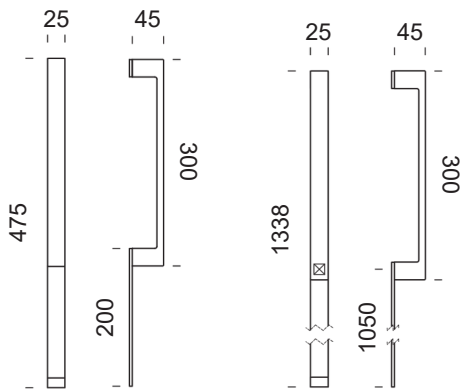

IF29 - singolo
IF30 - set

IF31 - singolo
IF32 - set



maniglione personalizzabile
customizable pull handle

ZEPPELIN

design:
Jaime Hayon
made in italy

Ottone
Brass



PVD-BG | forte®
Oroantico lucido
Antique brightgold



PVD-SG | forte®
Oro antico satinato
Antique satin gold



PVN | forte®
Nickel lucido
Bright nickel



PGS | forte®
Grafite satinato
Satin graphite



OC
Cromo lucido
Polished chrome



OCS
Cromo satinato
Satin chrome



OVE
Verde
Green



ONO
Nero
Black

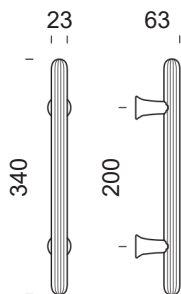

ZP27 - singolo
ZP28 - set



maniglione personalizzabile
customizable pull handle

ELEONORA

design:
Marco Pisati
made in italy

Ottone
Brass



PVD-BG | forte®
Oroantico lucido
Antique brightgold



PVD-SG | forte®
Oro antico satinato
Antique satin gold



PVN | forte®
Nickel lucido
Bright nickel



PGS | forte®
Grafite satinato
Satin graphite



OGH
Bronzo satinato opaco
Matt satin bronze



BSO
Bronzo sabbato opaco
Matt sandblasted bronze



OCS
Cromo satinato
Satin chrome

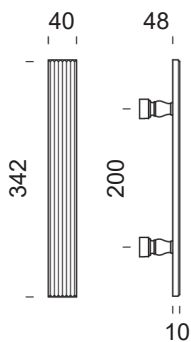

EL27 - singolo
EL28 - set



maniglione personalizzabile
customizable pull handle

ELEONORA

design:
Marco Pisati
made in italy

Ottone
Brass



PVD-BG | forte®
Oroantico lucido
Antique brightgold



PVD-SG | forte®
Oro antico satinato
Antique satin gold



PVN | forte®
Nickel lucido
Bright nickel



PGS | forte®
Grafite satinato
Satin graphite



OGH
Bronzo satinato opaco
Matt satin bronze



BSO
Bronzo sabbato opaco
Matt sandblasted bronze



OCS
Cromo satinato
Satin chrome

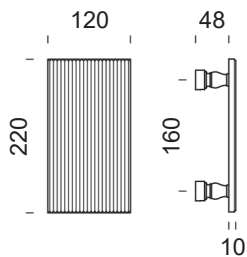

EL29 - singolo
EL30 - set

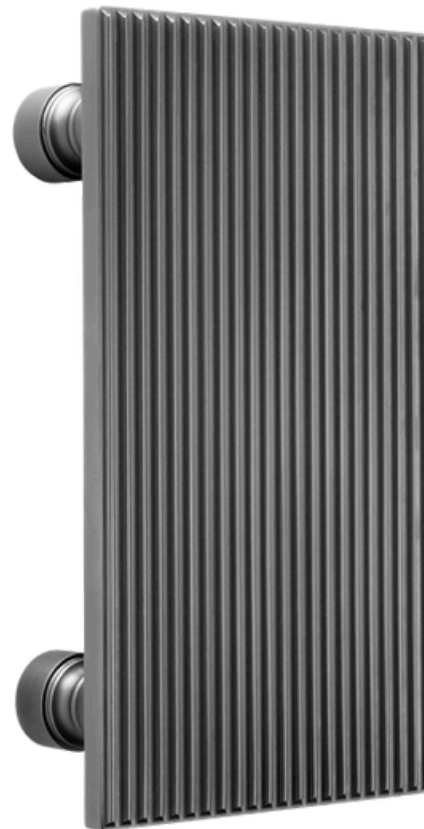

maniglione personalizzabile
customizable pull handle

ELEONORA

design:
Marco Pisati
made in italy

Ottone
Brass



PVD-BG | forte®
Oroantico lucido
Antique brightgold



PVD-SG | forte®
Oro antico satinato
Antique satin gold



PVN | forte®
Nickel lucido
Bright nickel



PGS | forte®
Grafite satinato
Satin graphite



OGH
Bronzo satinato opaco
Matt satin bronze



BSO
Bronzo sabbato opaco
Matt sandblasted bronze



OCS
Cromo satinato
Satin chrome

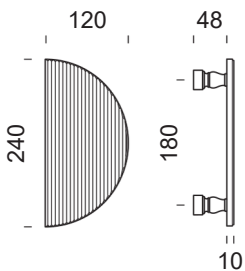

EL31 - singolo
EL32 - set

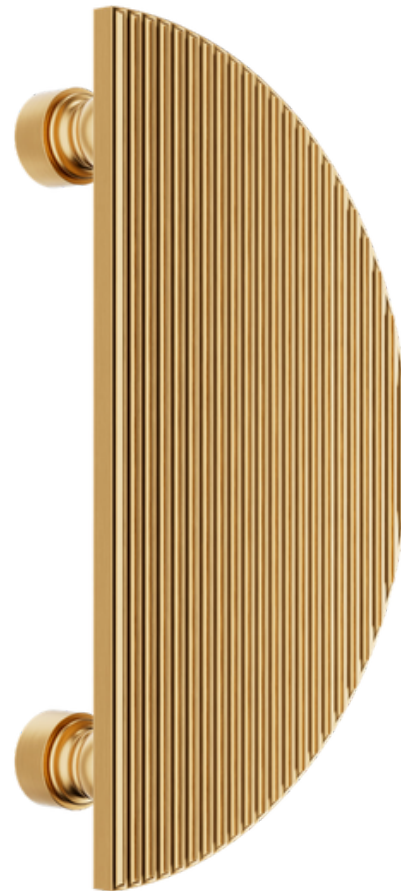

GINKGO

design:
Giulio Iacchetti
made in italy

Ottone
Brass



PVD-BG | forte®
Oroantico lucido
Antique brightgold



PVD-SG | forte®
Oro antico satinato
Antique satin gold



PVD-SH | forte®
Oro champagne satinato
Champagne satin gold



PVD-SB | forte®
Bronzo satinato
Satin bronze



PVN | forte®
Nickel lucido
Bright nickel



PGS | forte®
Grafite satinato
Satin graphite



OC
Cromo lucido
Polished chrome



OCS
Cromo satinato
Satin chrome



ONO
Nero
Black

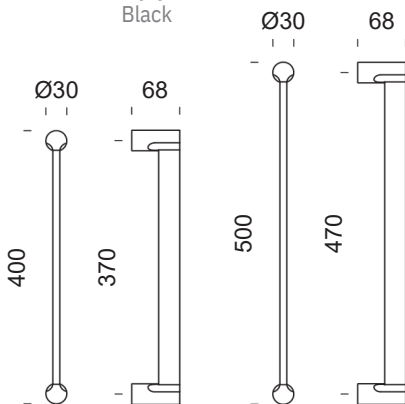

GK27 - singolo (400 mm)

GK28 - set (400 mm)

GK29 - singolo (500 mm)

GK30 - set (500 mm)



maniglione personalizzabile
customizable pull handle

GINKGO BILOBA

design:
Giulio Iacchetti
made in italy

Ottone
Brass



PVD-BG | forte®
Oro antico lucido
Antique bright gold



PVD-SG | forte®
Oro antico satinato
Antique satin gold



PVD-SH | forte®
Oro champagne satinato
Champagne satin gold



PVD-SB | forte®
Bronzo satinato
Satin bronze



PVN | forte®
Nickel lucido
Bright nickel



PGS | forte®
Grafite satinato
Satin graphite



OC
Cromo lucido
Polished chrome



OCS
Cromo satinato
Satin chrome



ONO
Nero
Black

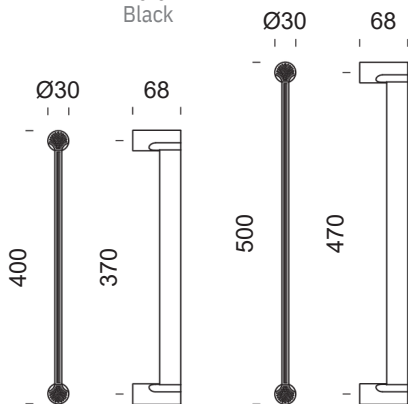

GB27 - singolo (400 mm)

GB28 - set (400 mm)

GB29 - singolo (500 mm)

GB30 - set (500 mm)



maniglione personalizzabile
customizable pull handle

LUCREZIA

design:
Marco Pisati
made in italy

Ottone
Brass



PVD-BG | forte®
Oroantico lucido
Antique brightgold



PVD-SG | forte®
Oro antico satinato
Antique satin gold



PVN | forte®
Nickel lucido
Bright nickel



PGS | forte®
Grafite satinato
Satin graphite



OGH
Bronzo satinato opaco
Matt satin bronze



BSO
Bronzo sabbato opaco
Matt sandblasted bronze



OCS
Cromo satinato
Satin chrome

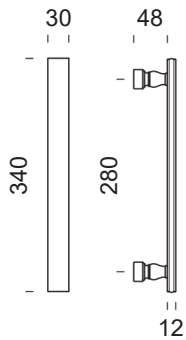

LT27 - singolo
LT28 - set



maniglione personalizzabile
customizable pull handle

CLOE

design:
Dnd technical division
made in italy

Ottone
Brass

ON DEMAND



PGS | forte®
Grafite satinato
Satin graphite



OC
Cromo lucido
Polished chrome



OCS
Cromo satinato
Satin chrome



ONO
Nero
Black

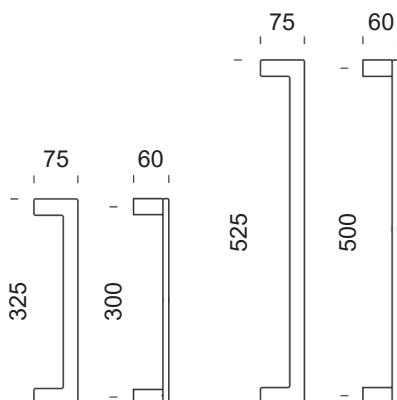

CL27 - singolo (300 mm)
CL28 - set (300 mm)
CL29 - singolo (500 mm)
CL30 - set (500 mm)



maniglione personalizzabile
customizable pull handle

ARETÈ

design:
Mauro Ronchi
made in italy

Ottone
Brass



PVD-SG|forte®

Oro antico satinato
Antique satin gold



PGS | forte®

Grafite satinato
Satin graphite



AB

Bronzato
Antique bronze



OCS

Cromo satinato
Satin chrome

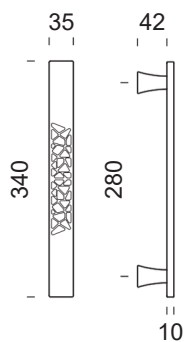

AT27 - singolo
AT28 - set

maniglione personalizzabile
customizable pull handle

ARETÈ L

design:
Mauro Ronchi
made in italy

Ottone
Brass



PVD-SG|forte®
Oro antico satinato
Antique satin gold



PGS|forte®
Grafite satinato
Satin graphite



AB
Bronzato
Antique bronze



OCS
Cromo satinato
Satin chrome

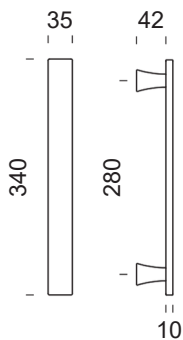

AL27 - singolo
AL28 - set



maniglione personalizzabile
customizable pull handle

DOMUS

design:
Dnd technical division
made in italy

Ottone
Brass

ON DEMAND



OLV
Lucido
Polished



OCS
Cromo satinato
Satin chrome



OGH
Bronzo satinato opaco
Matt satin bronze

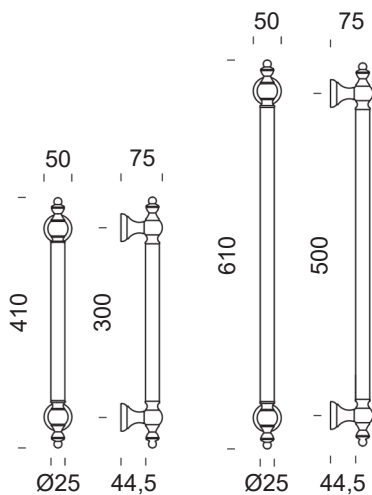

DO27/300 - singolo
DO26/300 - set
DO27/500 - singolo
DO26/500 - set



maniglione personalizzabile
customizable pull handle

SOLID SQUARE

design:
Dnd technical division
made in italy

Ottone
Brass



PG5 | forte®
Grafite satinato
Satin graphite



OC
Cromo lucido
Polished chrome



OCS
Cromo satinato
Satin chrome



ONO
Nero
Black

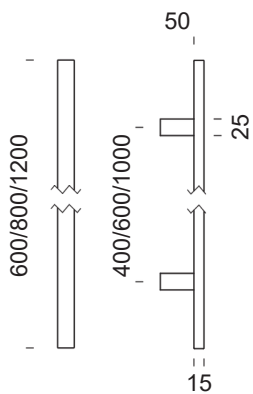

singolo
SQ400
SQ600
SQ1000

set
SQ401
SQ601
SQ1001



maniglione personalizzabile
customizable pull handle

TUBE ROUND

design:
Dnd technical division
made in italy

Ottone
Brass



PVD-SG | forte®
Oroantico satinato
Antique satingold



PGS | forte®
Grafite satinato
Satin graphite



OCS
Cromo satinato
Satin chrome



ONO
Nero
Black

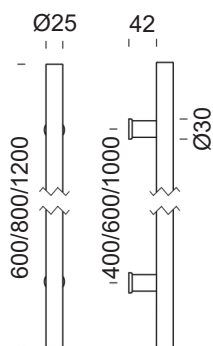

singolo
TR400
TR600
TR1000

set
TR401
TR601
TR1001
1



maniglione personalizzabile
customizable pull handle

TUBE ROUND ZANCATO

design:
Dnd technical division
made in italy

Ottone
Brass



PVD-SG | forte®
Oroantico satinato
Antique satingold



PGS | forte®
Grafite satinato
Satin graphite



OCS
Cromo satinato
Satin chrome



ONO
Nero
Black

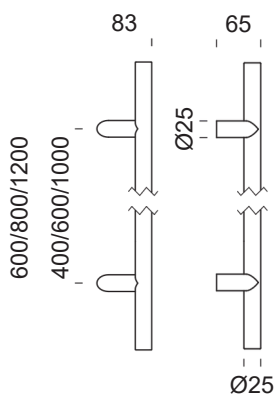

singolo
TZ400
TZ600
TZ1000

set
TZ401
TZ601
TZ100

1



maniglione personalizzabile
customizable pull handle

LUXURY

design:
Mauro Ronchi
made in italy

Ottone
Brass



PVD-BG | forte®
Oroantico lucido
Antique brightgold



PVD-SG | forte®
Oro antico satinato
Antique satin gold



PGS | forte®
Grafite satinato
Satin graphite



OGH
Bronzo satinato opaco
Matt satin bronze



OC
Cromo lucido
Polished chrome



OCS
Cromo satinato
Satin chrome



ONO
Nero
Black

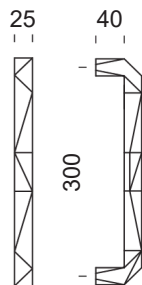

LU27 - singolo
LU28 - set



LOGO

design:
Mauro Ronchi
made in italy

Ottone
Brass



OC
Cromo lucido
Polished chrome



OCS
Cromo satinato
Satin chrome



ONS
Nickel satinato
Satin nickel

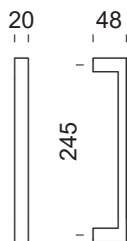

L025 - singolo
L026 - set

PROJECT

design:
Dnd technical division
made in italy

Ottone
Brass



OS
Satinato
Satin



AB
Bronzato
Antique bronze



OCS
Cromo satinato
Satin chrome



ONS
Nickel satinato
Satin nickel



ONO
Nero
Black

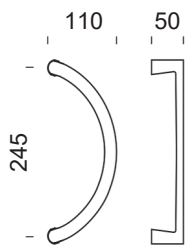
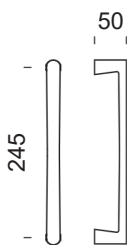

PROJECT
PR29 - singolo
PR26 - set

PROJECT SPOSTATO
PR27 - singolo
PR28 - set

LUCE

design:
Dnd technical division

Zama
Zamak

made in italy



ZOR
Oro lucido
Brightpolished



ZC
Cromo lucido
Polished chrome



ZCS
Cromo satinato
Satin chrome



ZNS
Nickel satinato
Satin nickel



ZBN
Bianco
White



ZAN
Antracite
Anthracite



ZNE
Nero
Black



ZRO
Oro satinato
Satin gold



ZBR
Bronzo
Bronze

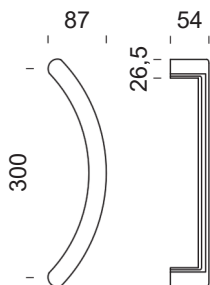

LC26 - singolo
LC28 - set



LATINA

design:
Mauro Ronchi
made in italy

Ottone
Brass

ON DEMAND



OLV
Lucido
Polished

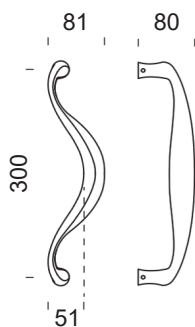

1110 - singolo
1111 - set

DANIELA

design:
Dnd technical division
made in italy

Ottone
Brass



OLV
Lucido
Polished



OGH
Bronzo satinato opaco
Matt satin bronze



AB
Bronzato
Antique bronze



ONV
Nickel lucido
Polished nickel

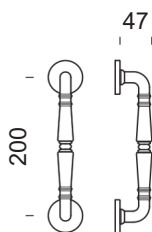

DANIELA
1150 - singolo

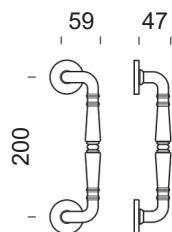

DANIELA SPOSTATO
1170 - singolo spostato

MANIGLIONI PER ALZANTE SCORREVOLE

PULL HANDLES FOR LIFT SLIDING SYSTEM

EDRA 02

design:
Mauro Ronchi
made in italy

Ottone
Brass



PVD-SG | forte®
Oroantico satinato
Antique satinalgold



PVD-SH | forte®
Oro champagne satinato
Champagne satin gold



PVD-SB | forte®
Bronzo satinato
Satin bronze



PGS | forte®
Grafite satinato
Satin graphite



OGH
Bronzo satinato opaco
Matt satin bronze



OC
Cromo lucido
Polished chrome



OCS
Cromo satinato
Satin chrome



ONS
Nickel satinato
Satin nickel



ONO
Nero
Black

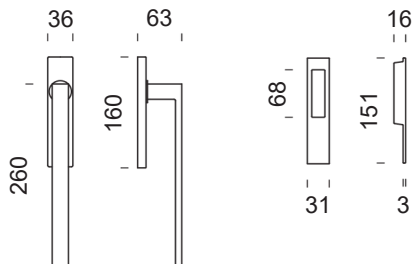

ED60 - singolo
ED61 - set

EDRA 02 CORTO

design:
Mauro Ronchi
made in italy

Ottone
Brass



PVD-SG | forte®
Oroantico satinato
Antique satingold



PVD-SH | forte®
Oro champagne satinato
Champagne satin gold



PVD-SB | forte®
Bronzo satinato
Satin bronze



PGS | forte®
Grafite satinato
Satin graphite



OGH
Bronzo satinato opaco
Matt satin bronze



OC
Cromo lucido
Polished chrome



OCS
Cromo satinato
Satin chrome



ONS
Nickel satinato
Satin nickel



ONO
Nero
Black

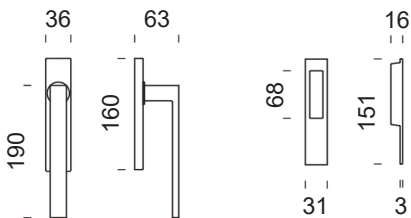

ED63A - singolo
ED64 - set

EDRA

design:
Mauro Ronchi
made in italy

Ottone
Brass



PVD-SG | forte®
Oroantico satinato
Antique satin gold



PVD-SH | forte®
Oro champagne satinato
Champagne satin gold



PVD-SB | forte®
Bronzo satinato
Satin bronze



PGS | forte®
Grafite satinato
Satin graphite



OGH
Bronzo satinato opaco
Matt satin bronze



OC
Cromo lucido
Polished chrome



OCS
Cromo satinato
Satin chrome



ONS
Nickel satinato
Satin nickel



ONO
Nero
Black

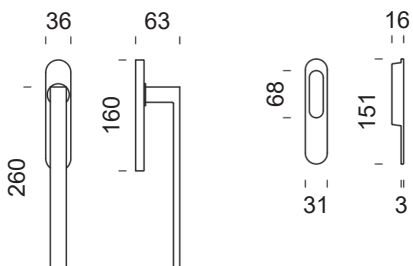

ED50 - singolo
ED51 - set

EDRA CORTO

design:
Mauro Ronchi
made in italy

Ottone
Brass



PVD-SG | forte®
Oroantico satinato
Antique satingold



PVD-SH | forte®
Oro champagne satinato
Champagne satin gold



PVD-SB | forte®
Bronzo satinato
Satin bronze



PGS | forte®
Grafite satinato
Satin graphite



OGH
Bronzo satinato opaco
Matt satin bronze



OC
Cromo lucido
Polished chrome



OCS
Cromo satinato
Satin chrome



ONS
Nickel satinato
Satin nickel



ONO
Nero
Black

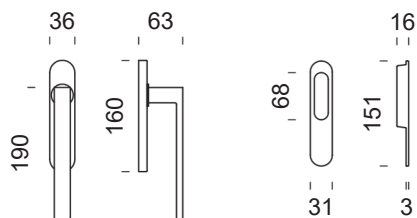

ED53 - singolo
ED54 - set

SLIDE

design:
Mauro Ronchi
made in italy

Ottone
Brass



PVD-SG | forte®
Oroantico satinato
Antique satinalgold



PVD-SB | forte®
Bronzo satinato
Satin bronze



PGS | forte®
Grafite satinato
Satin graphite



OCS
Cromo satinato
Satin chrome

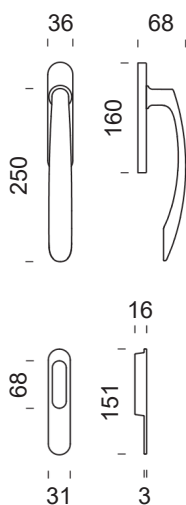

1120 - singolo
1121 - set

SLIDE CORTO

design:
Mauro Ronchi
made in italy

Ottone
Brass



PVD-SG | forte®
Oroantico satinato
Antique satingold



PVD-SB | forte®
Bronzo satinato
Satin bronze



PGS | forte®
Grafite satinato
Satin graphite



OCS
Cromo satinato
Satin chrome

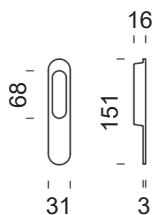
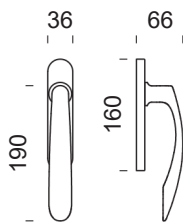

1125 - singolo
1126 - set
1127 - DK



LUCE P

design:
Dnd technical division
made in italy

Zama
Zamak



ZOR
Oro lucido
Brightpolished



ZC
Cromo lucido
Polished chrome



ZCS
Cromo satinato
Satin chrome



ZNS
Nickel satinato
Satin nickel



ZBN
Bianco
White



ZAN
Antracite
Anthracite



ZNE
Nero
Black



ZRO
Oro satinato
Satin gold



ZBR
Bronzo
Bronze

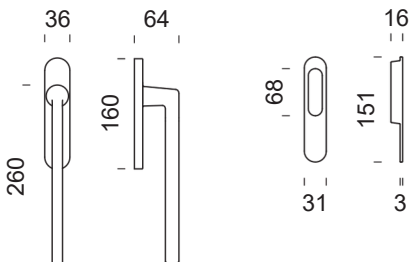

LP50 - singolo
LP51 - set

LUCE P 02

design:
Dnd technical division
made in italy

Zama
Zamak

-  **ZC**
Cromo lucido
Polished chrome
-  **ZCS**
Cromo satinato
Satin chrome
-  **ZNS**
Nickel satinato
Satin nickel
-  **ZBN**
Bianco
White
-  **ZAN**
Antracite
Anthracite
-  **ZNE**
Nero
Black
-  **ZRO**
Oro satinato
Satin gold
-  **ZBR**
Bronzo
Bronze

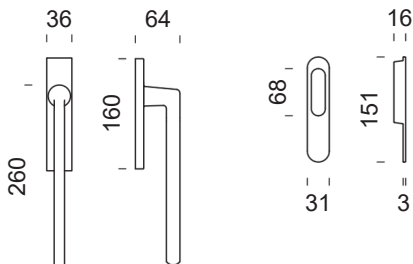

LP60 - singolo
LP61 - set

LUCE

design:
Dnd technical division
made in italy

Zama
Zamak



ZOR
Oro lucido
Brightpolished



ZC
Cromo lucido
Polished chrome



ZCS
Cromo satinato
Satin chrome



ZNS
Nickel satinato
Satin nickel



ZBN
Bianco
White



ZAN
Antracite
Anthracite



ZNE
Nero
Black



ZRO
Oro satinato
Satin gold



ZBR
Bronzo
Bronze

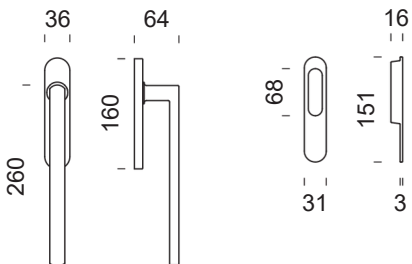

LC50 - singolo
LC51 - set

LUCE 02

design:
Dnd technical division
made in italy

Zama
Zamak

-  **ZC**
Cromo lucido
Polished chrome
-  **ZCS**
Cromo satinato
Satin chrome
-  **ZNS**
Nickel satinato
Satin nickel
-  **ZBN**
Bianco
White
-  **ZAN**
Antracite
Anthracite
-  **ZNE**
Nero
Black
-  **ZRO**
Oro satinato
Satin gold
-  **ZBR**
Bronzo
Bronze

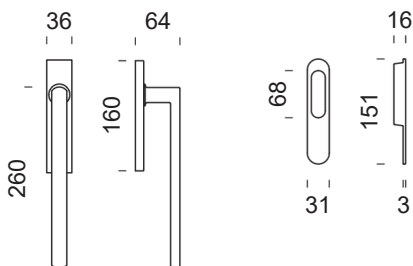

LC60 - singolo
LC61 - set

PLACCHE INCASSO

Ottone
Brass



PVD-SG | forte®
Oroantico satinato
Antique satinalgold



PVD-SB | forte®
Bronzo satinato
Satin bronze



PGS | forte®
Grafite satinato
Satin graphite



OC
Cromo lucido
Polished chrome



OCS
Cromo satinato
Satin chrome



ONS
Nickel satinato
Satin nickel



OBN
Bianco
White



TAN
Antracite
Anthracite



ONO
Nero
Black

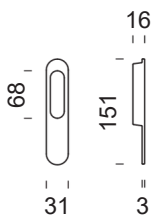

1122

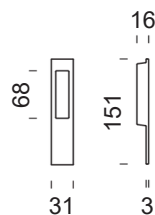

ED66

POMOLI

KNOBS

PALM

NEW

design:
BIG - Bjarke Ingels Group
made in italy

Ottone
Brass

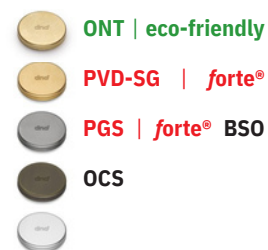

R PA39 - singolo
PA35 - set

PENCIL

NEW

design:
BIG - Bjarke Ingels Group
made in italy

Alluminio
Aluminium

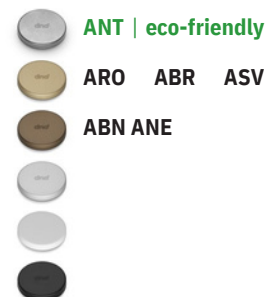
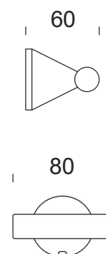
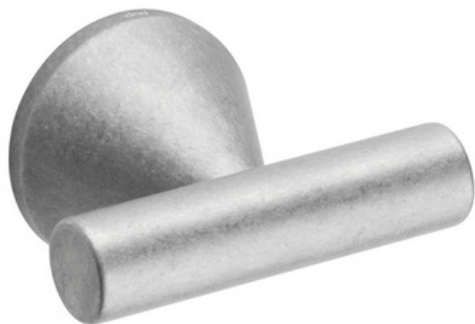

R PE39 - singolo

OLIVE NEW

design:
Park
made in italy

Ottone
Brass

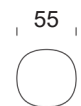
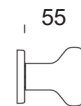

VIS OL39 - singolo
OL36 - set



RING

design:
Dnd technical division
made in italy

Ottone
Brass

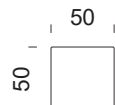
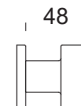

VIS RI39 - singolo
RI35 - set

